

RO835

PALENBOS (35 palen)
 LA JUNGLE (35 poteaux)
 THE JUNGLE (35 posts)
 PFAHLWALD (35 pfosten)
 LA SELVA (35 postes)
 BOSCHETTO DI PALETTI
 (35 messaggi)

Montagehandleiding
Notice de montage
Assembling manual
Montageanleitung
Instrucciones para el montaje
Istruzioni di installazione

Leeftijd:
 Age: 4-12
 Age group:
 Alter:
 Edad:
 Età:

EUROPLAY nv
 Eegene 9
 B-9200 DENDERMONDE
 tel. 32.52.22 66 22
 fax.32.52.22 67 22
 www.europlay.eu

Dat.: 2/10/2013

Page: 1/12

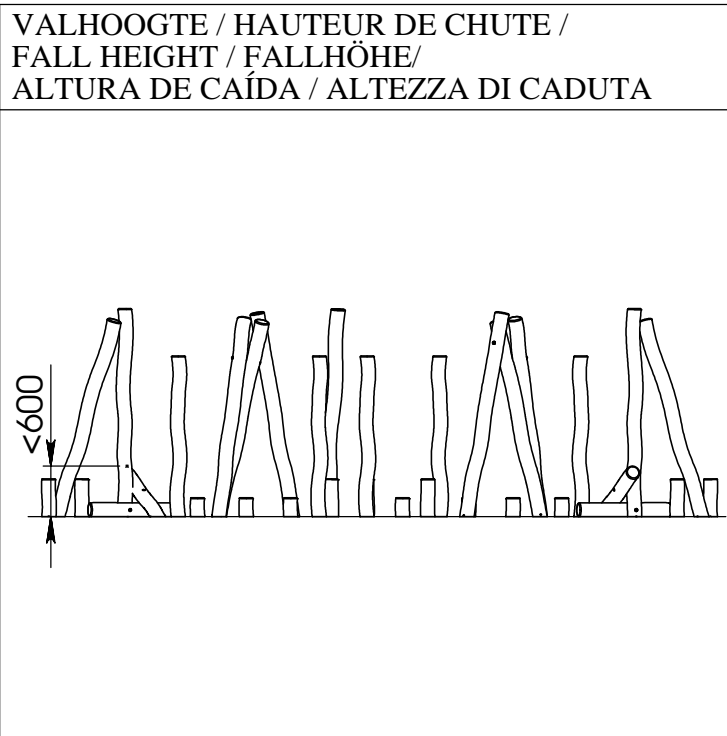
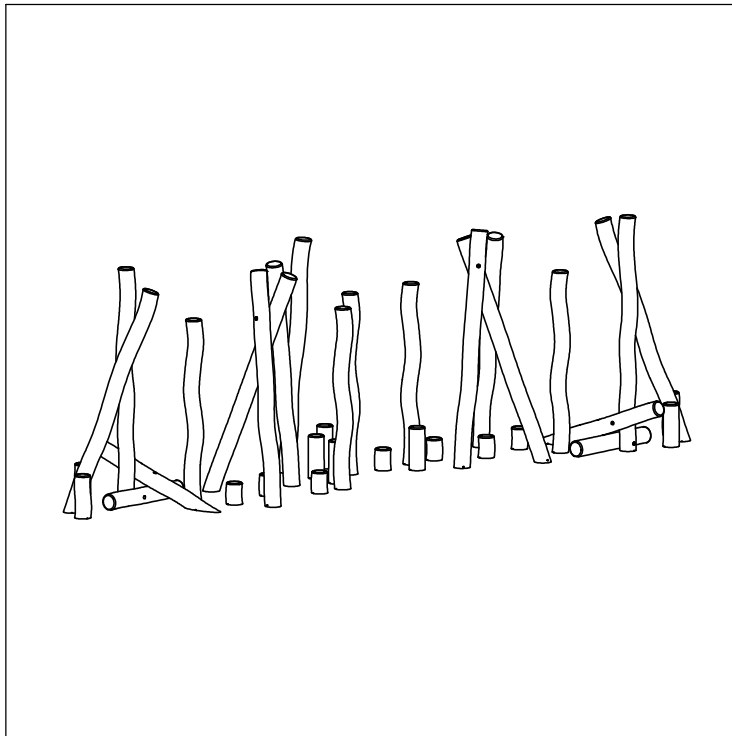

VEILIGHEIDSAFSTAND / ESPACE DE CHUTE / SAFETY AREA /
 SICHERHEITSAFSTAND / ZONA DE SEGURIDAD / DISTANZA DI SICUREZZA

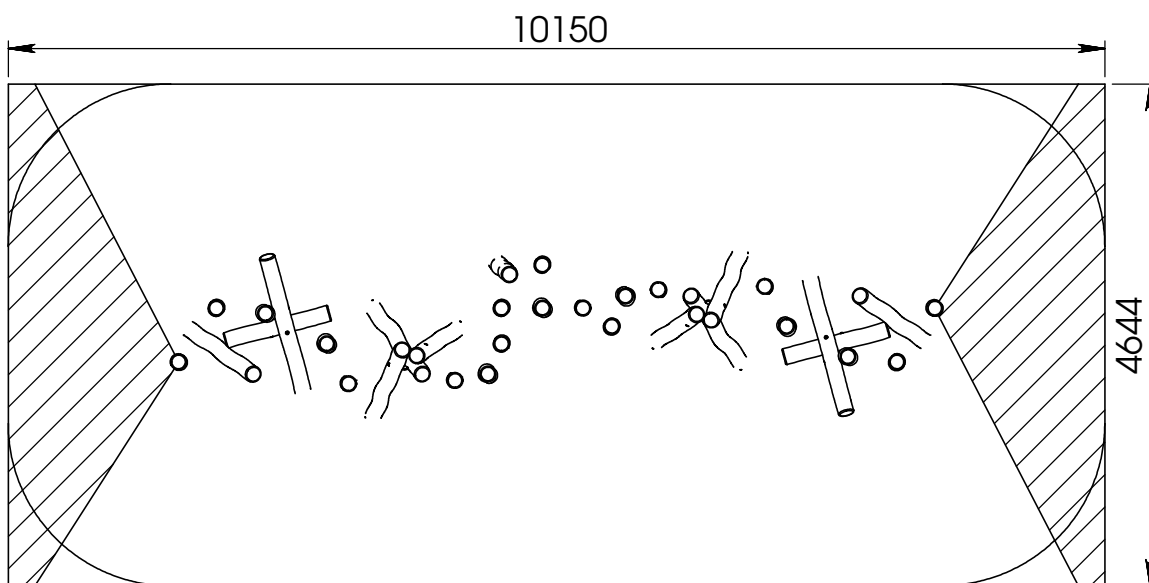



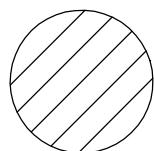







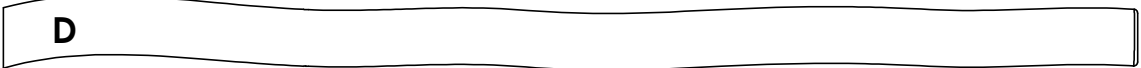

AFMETINGEN
 DIMENSIONS
 MASSE
 DIMENSIONES
 DIMENSIONI
 L : 7,2m
 H: 2,2m
 Br: 1,7m



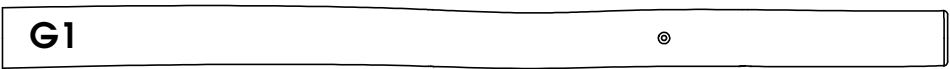

Samenvoegingszone
 Zone de liaison
 Verbindungsfeld
 Linking zone
 Zona de conexión
 Zona di allineamento

±48m2

Benodigdheden - Liste des pièces - Materials - Benötigtes - Accesorios - Requisiti

7x		8x	
	(800xØ140-Ø180) (±12kg)		(1000xØ140-Ø180) (±15kg)
5x			
	(2500xØ140-Ø180) (±36kg)		
3x			
	(3000xØ140-Ø180) (±44kg)		
1x			
	(3000xØ140-Ø180) (±44kg)		
1x			
	(3000xØ140-Ø180) (±44kg)		
1x		1x	
	(1000xØ140-Ø180) (±14kg)		(1000xØ140-Ø180) (±14kg)
1x			
	(2500xØ140-Ø180) (±37kg)		
1x			
	(2500xØ140-Ø180) (±37kg)		
1x			
	(3000xØ140-Ø180) (±44kg)		
1x			
	(3000xØ140-Ø180) (±44kg)		
1x			
	(3000xØ140-Ø180) (±44kg)		
1x			
	(3000xØ140-Ø180) (±44kg)		

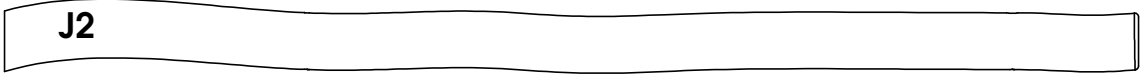
Benodigdheden - Liste des pièces - Materials - Benötigtes - Accesorios - Requisiti

1x		J1				
	(3000xØ140-Ø180)				(±44kg)	
1x		J2				
	(3000xØ140-Ø180)				(±44kg)	
6x		M12x200		6x		M12

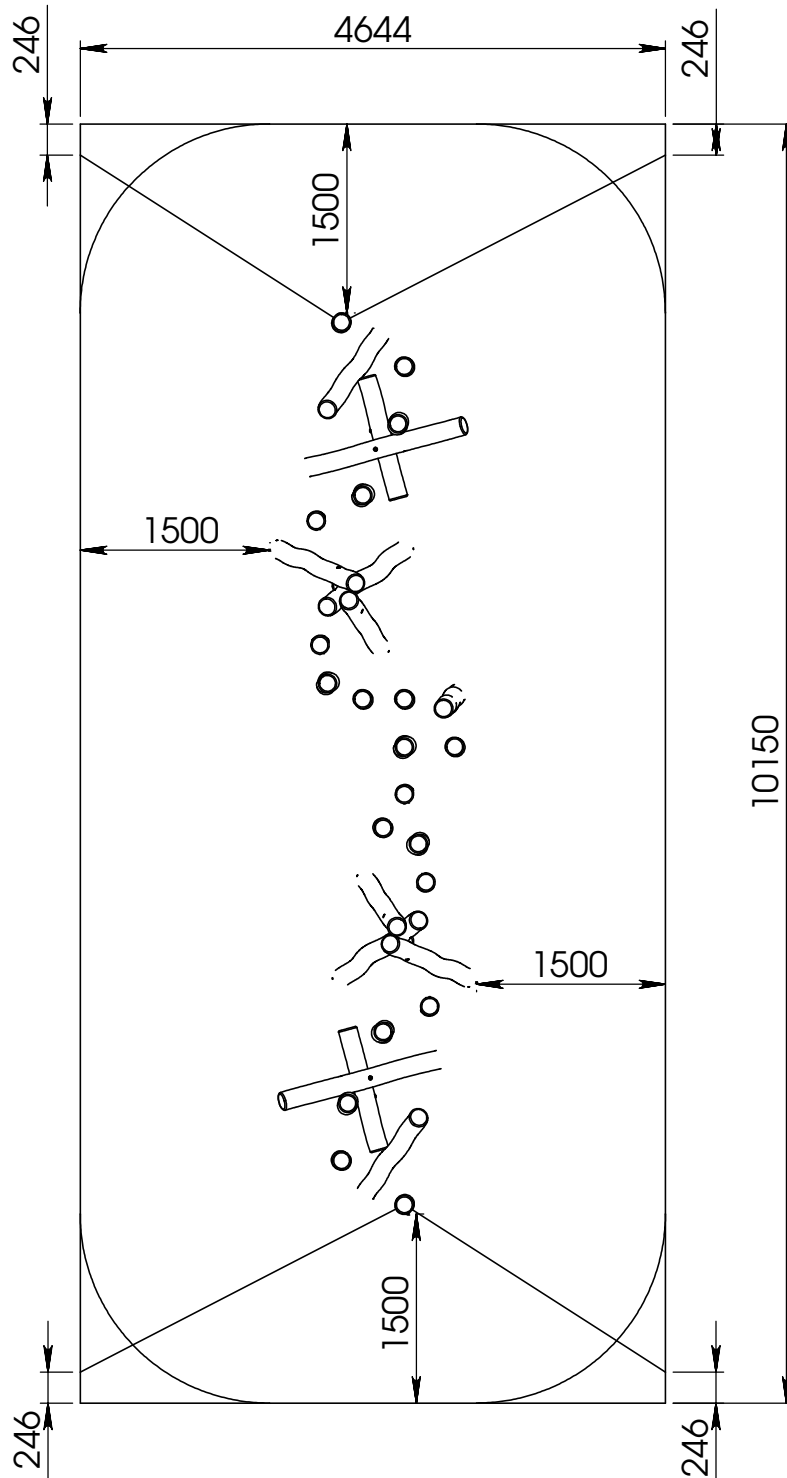

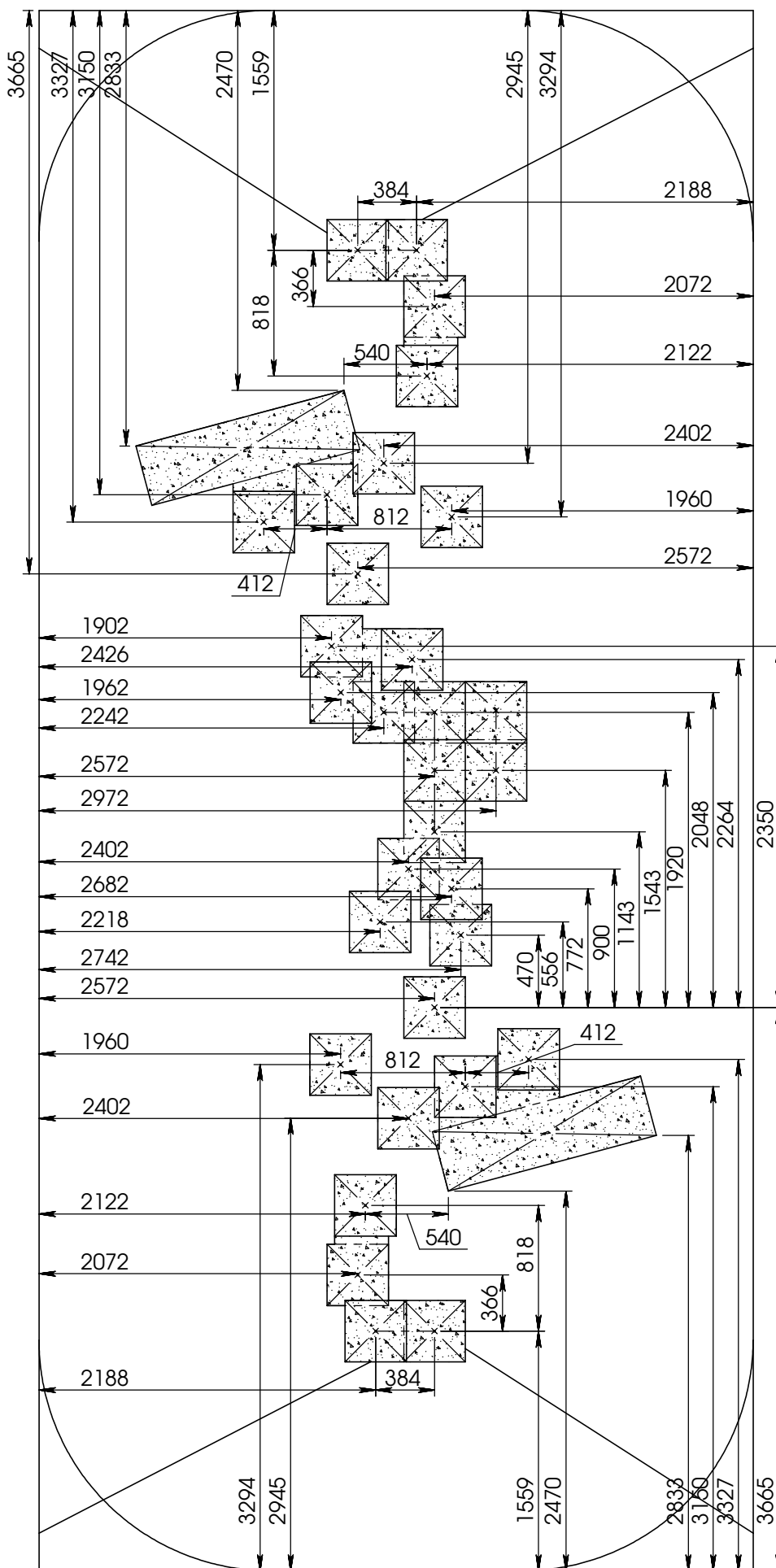

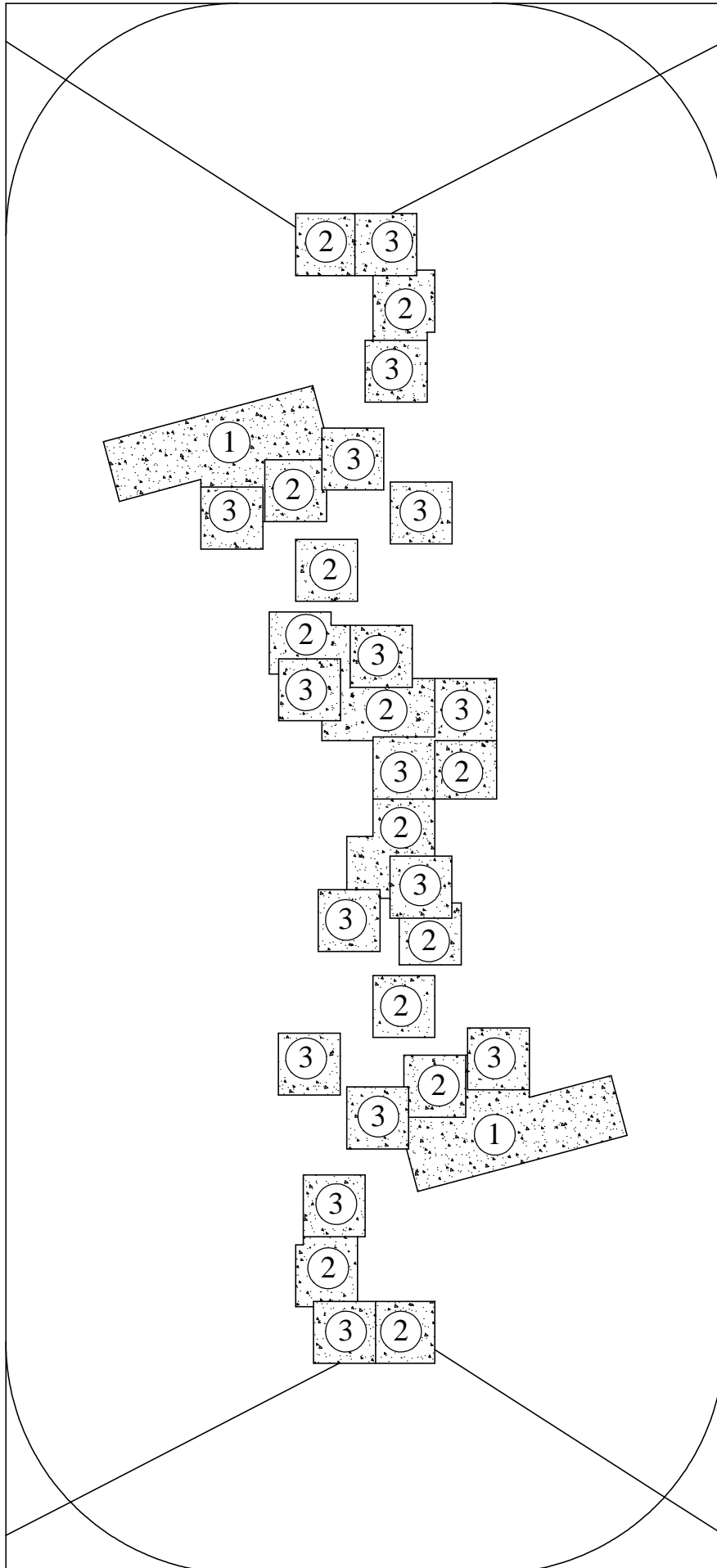

- ① ▽ 500
- ② ▽ 600
- ③ ▽ 800

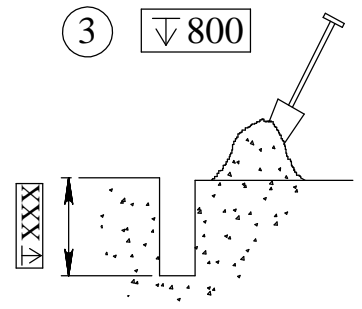

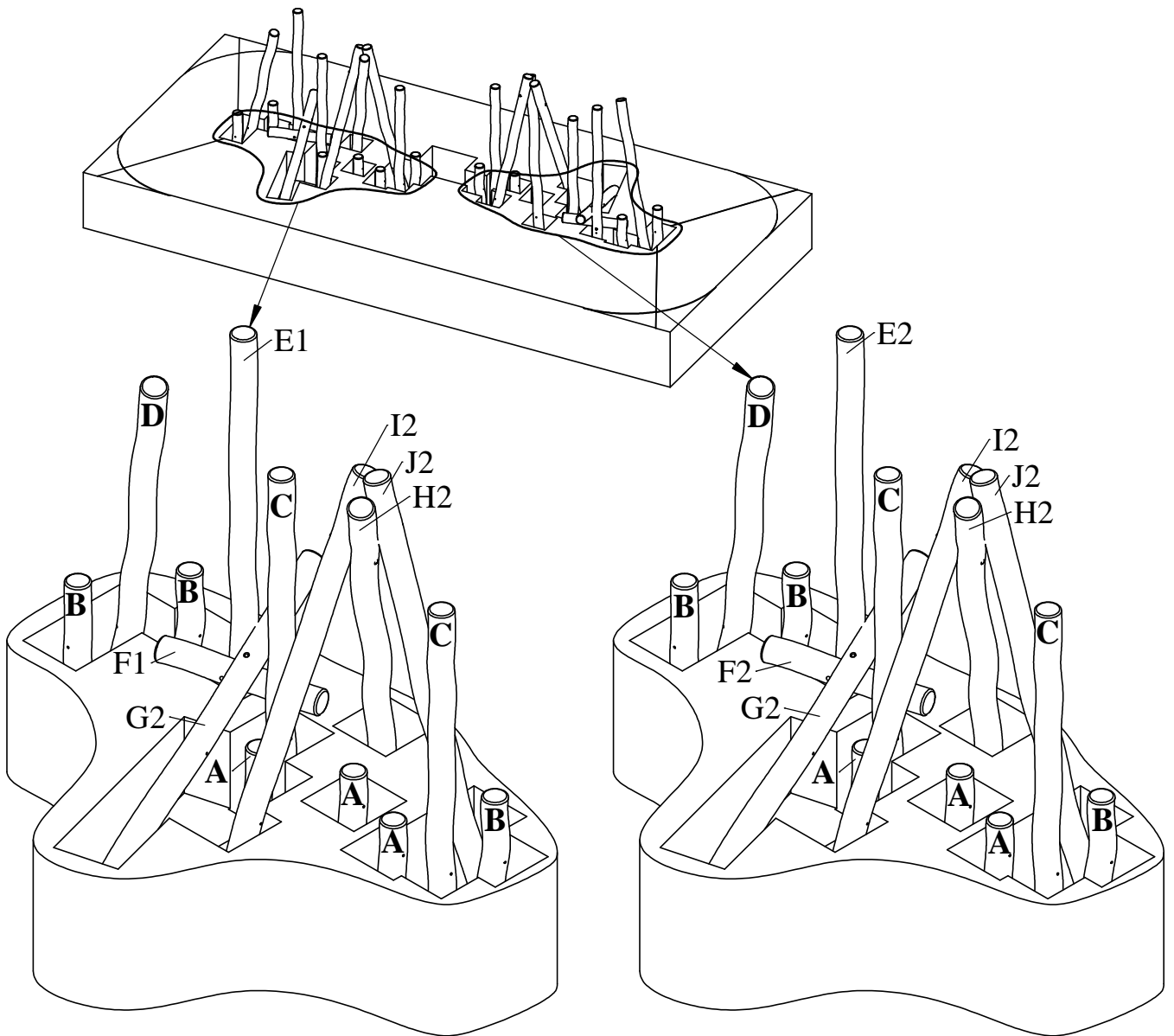
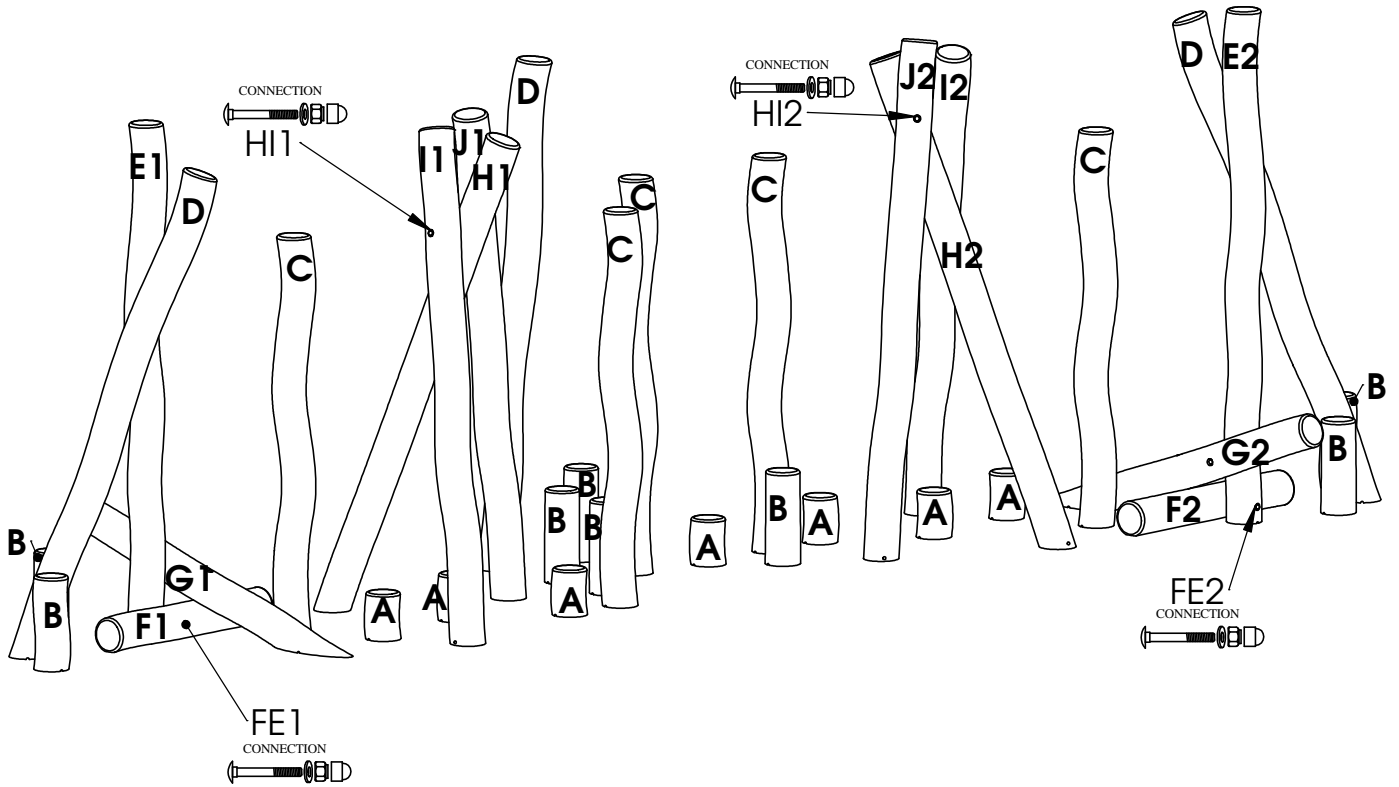

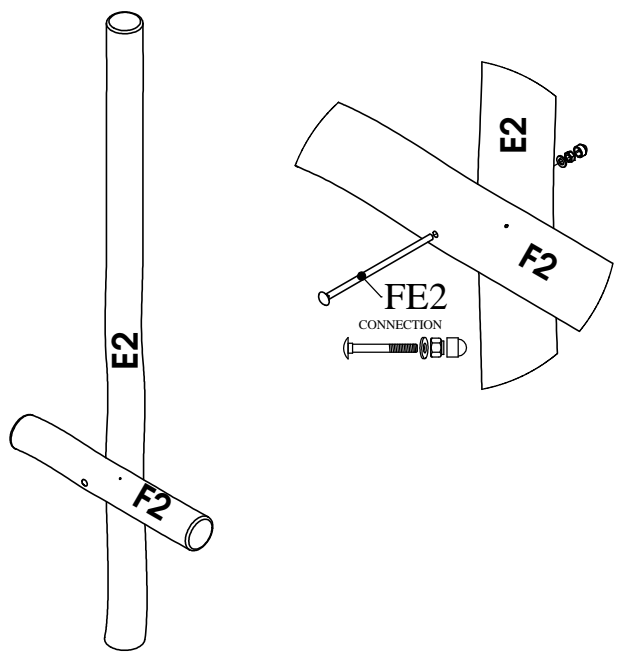
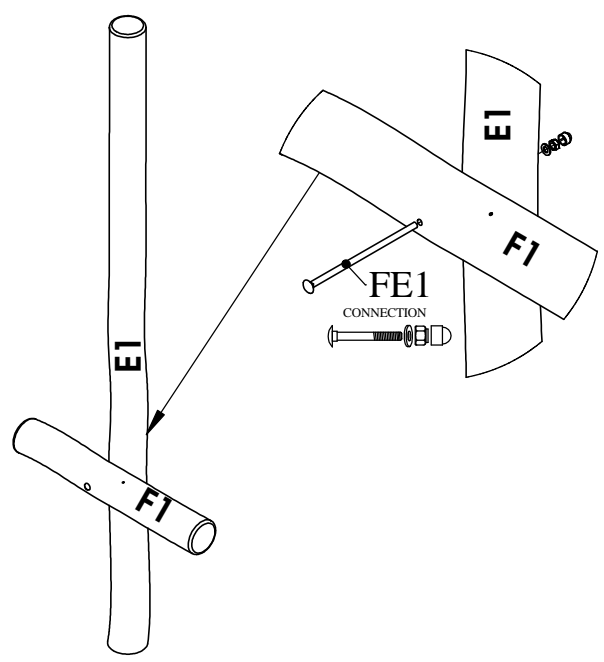
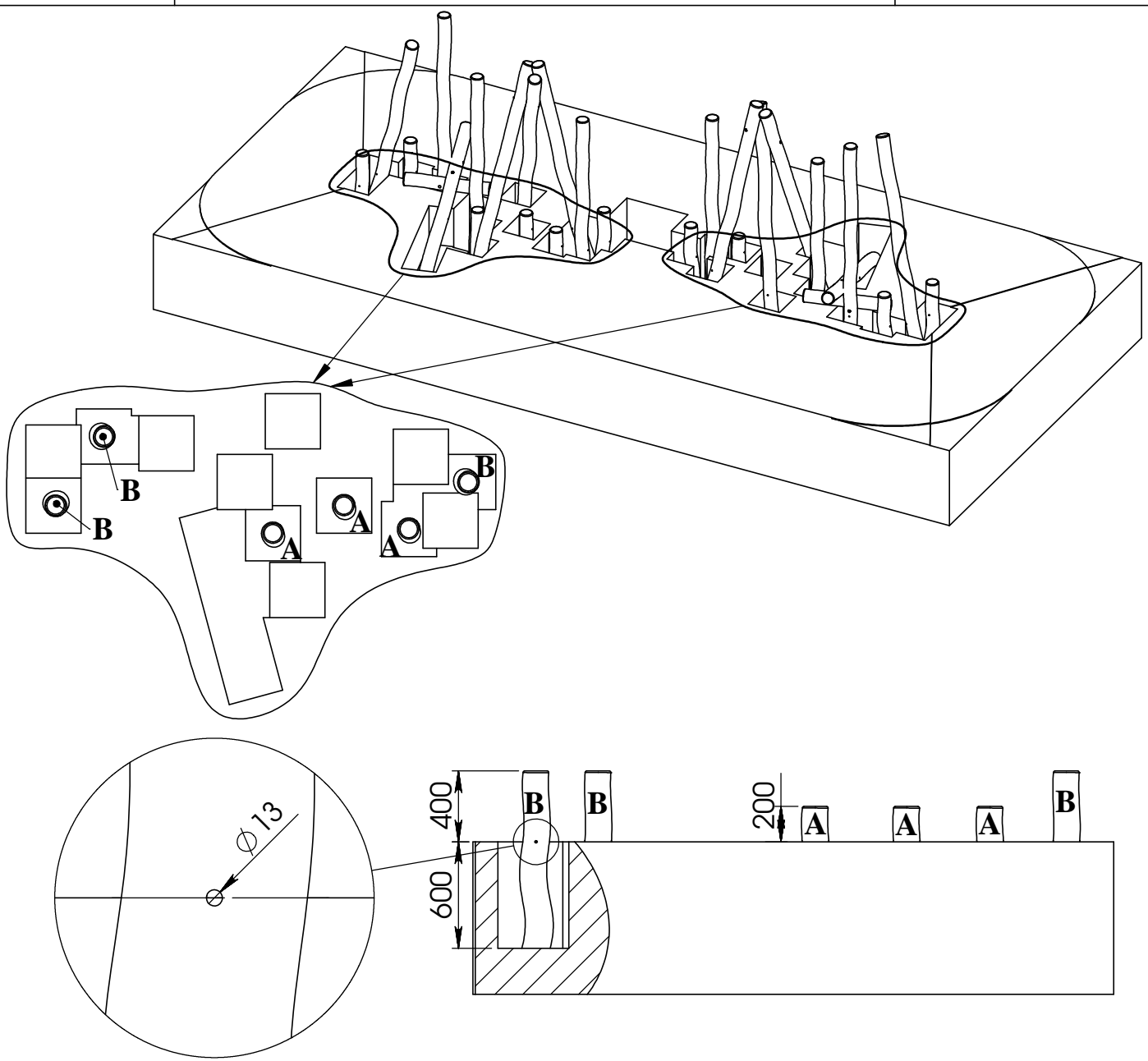

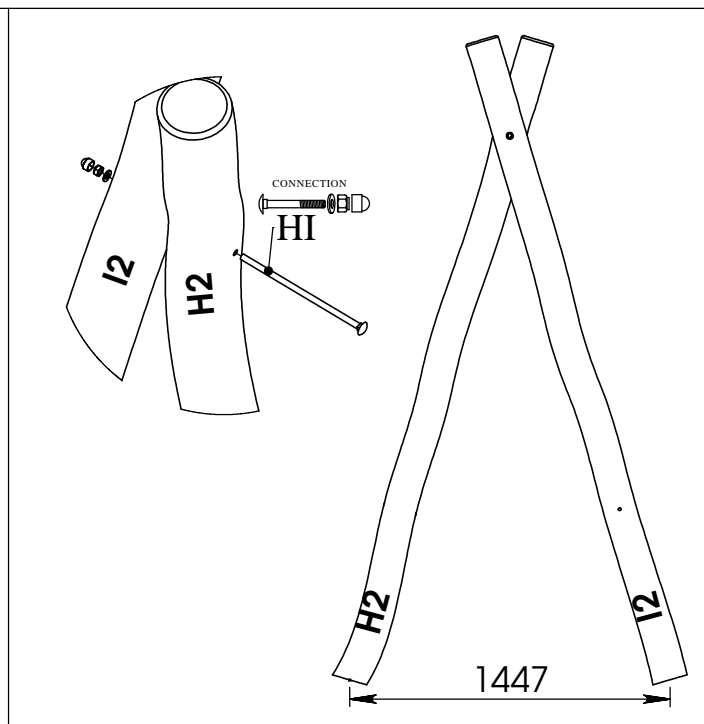
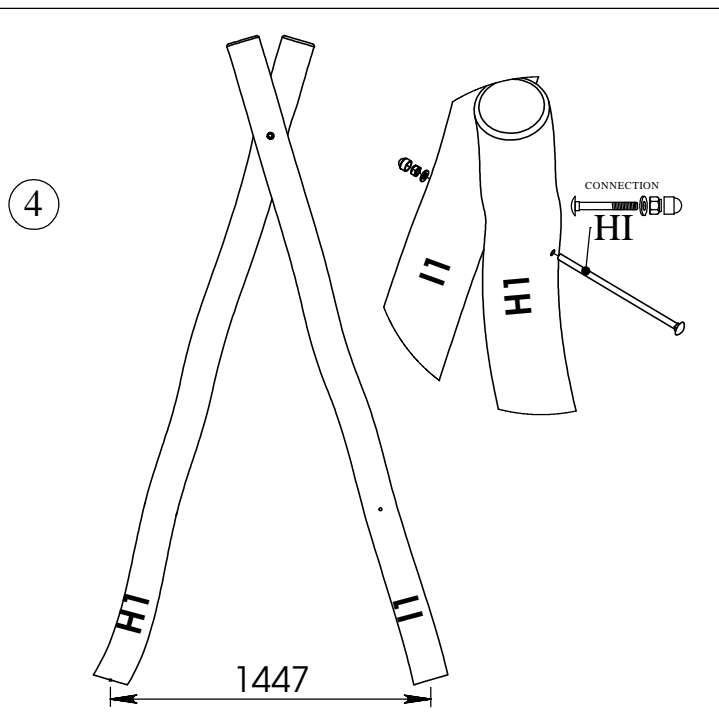
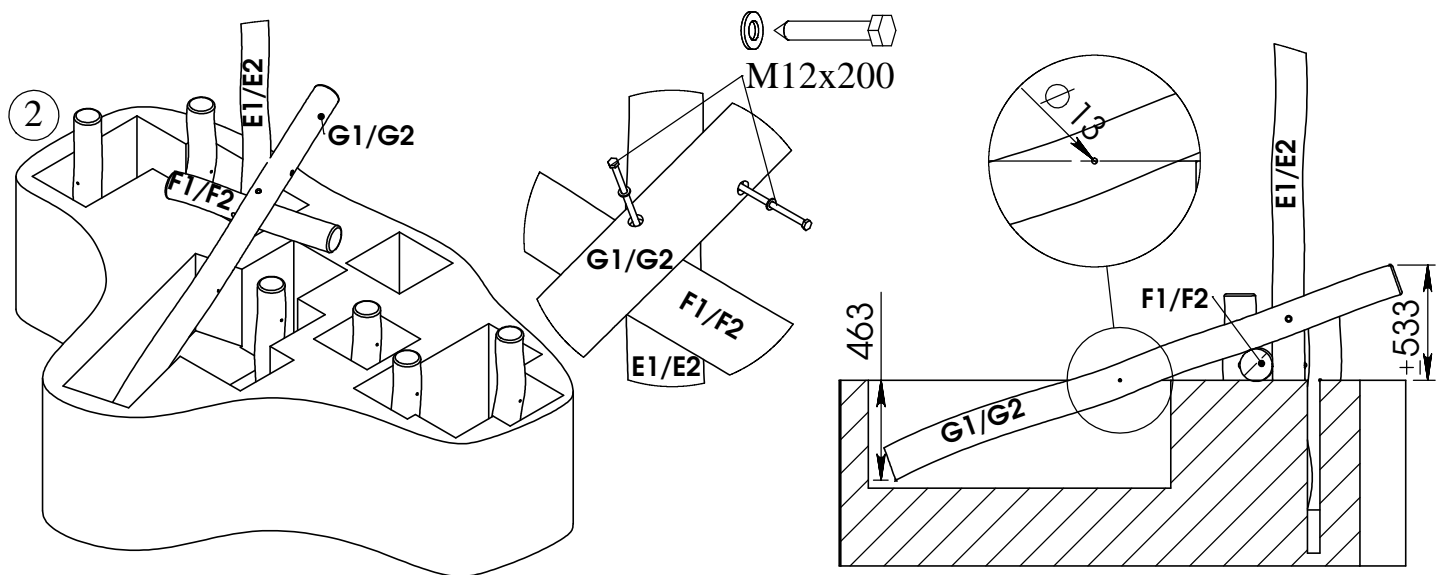
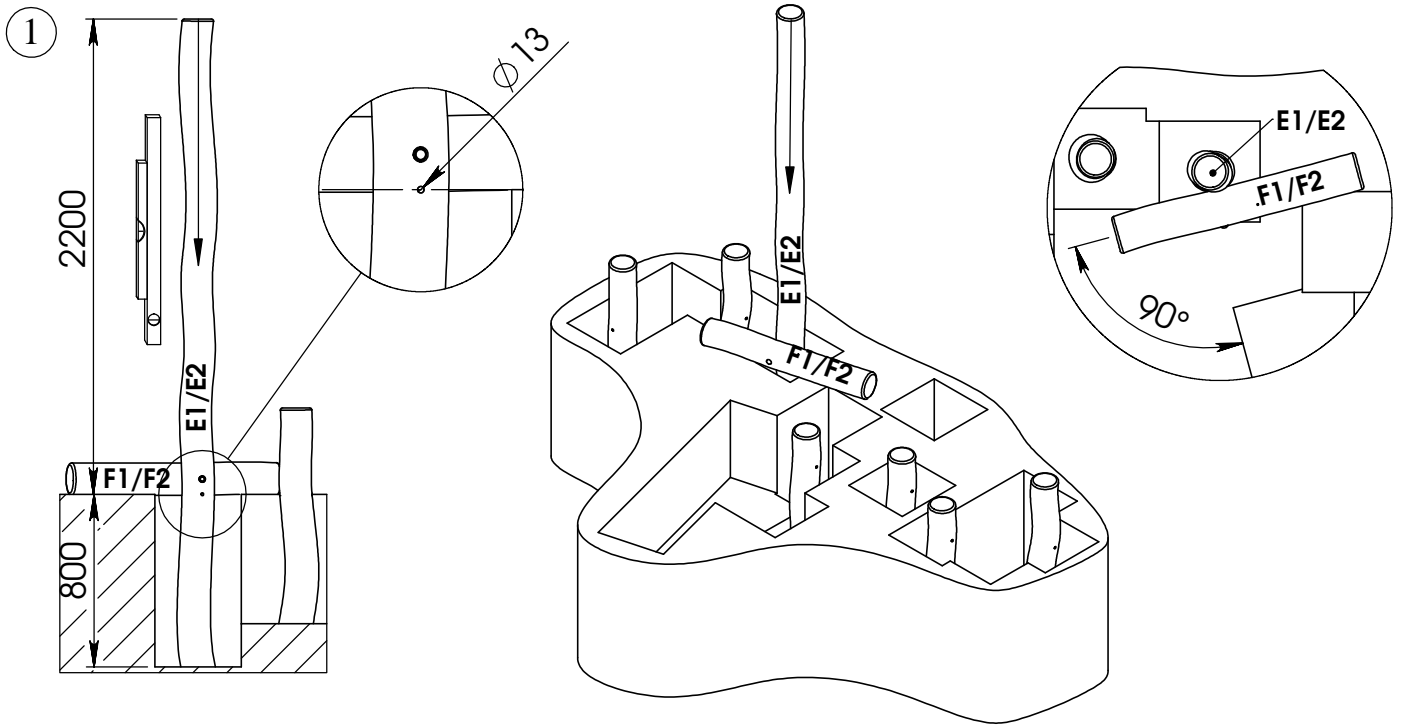

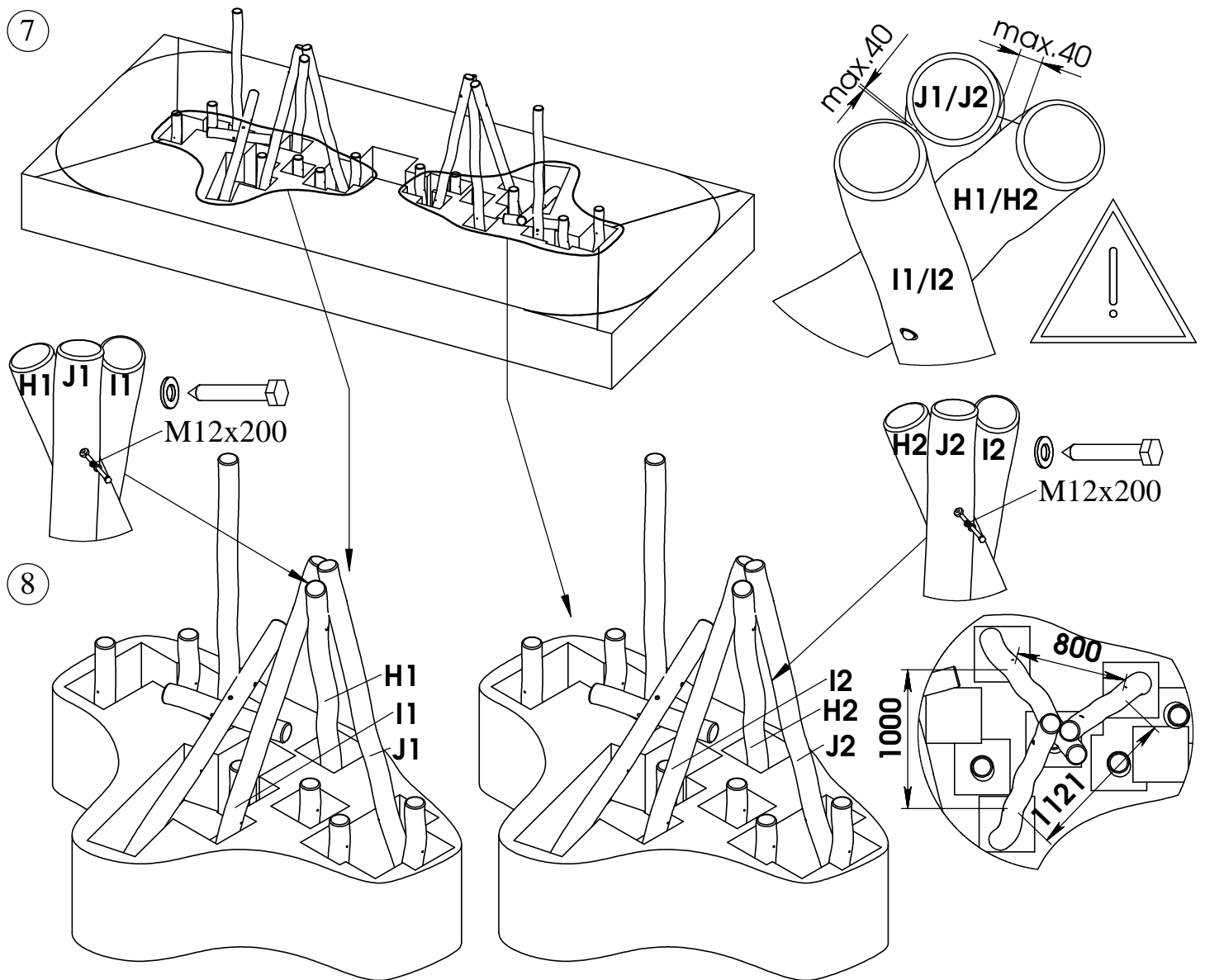
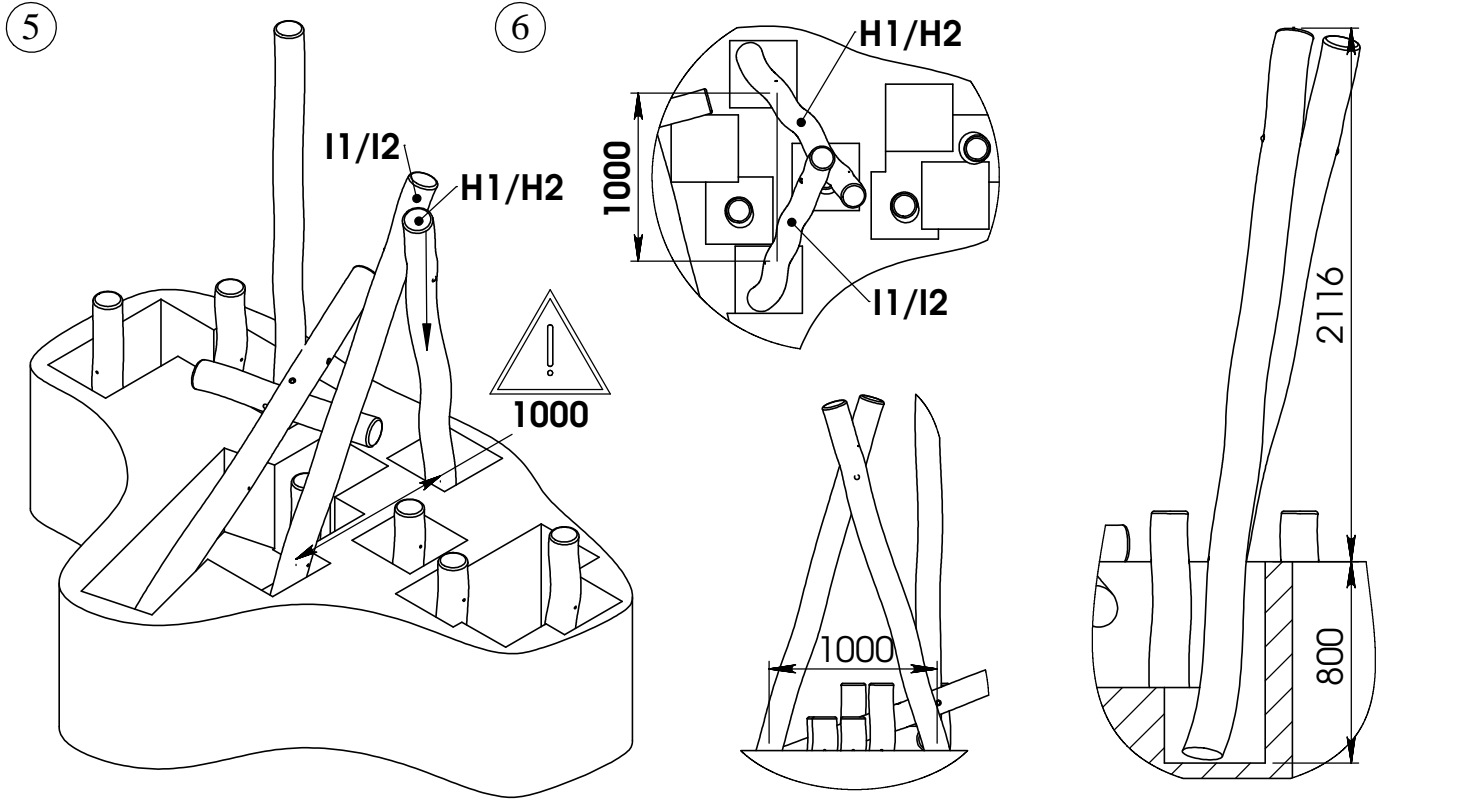

9

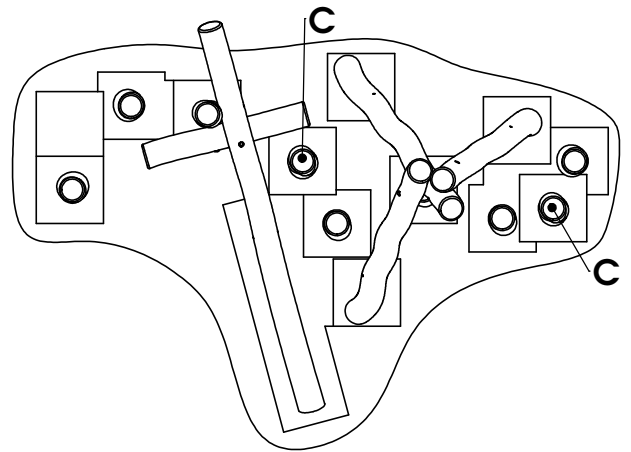
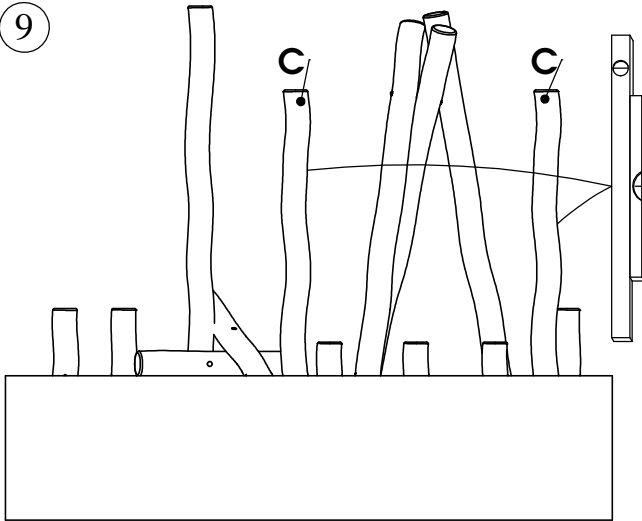

10

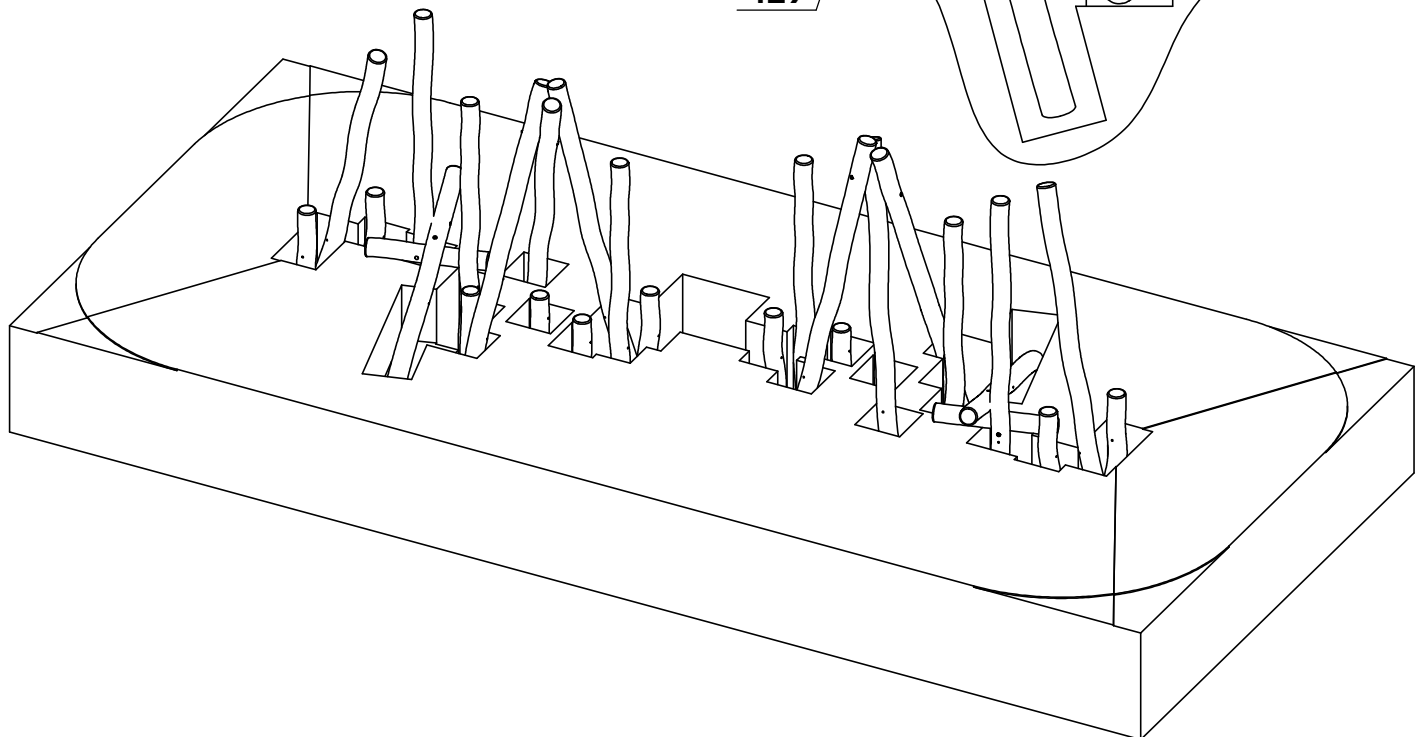
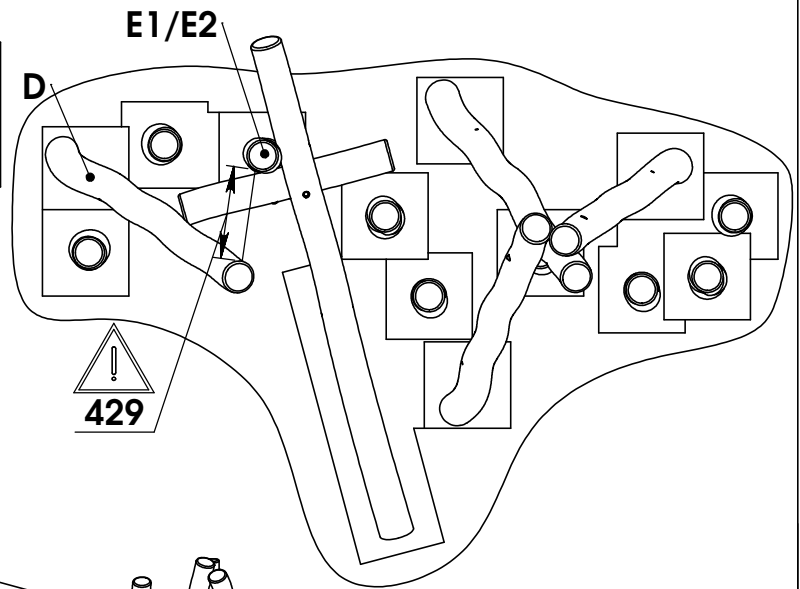
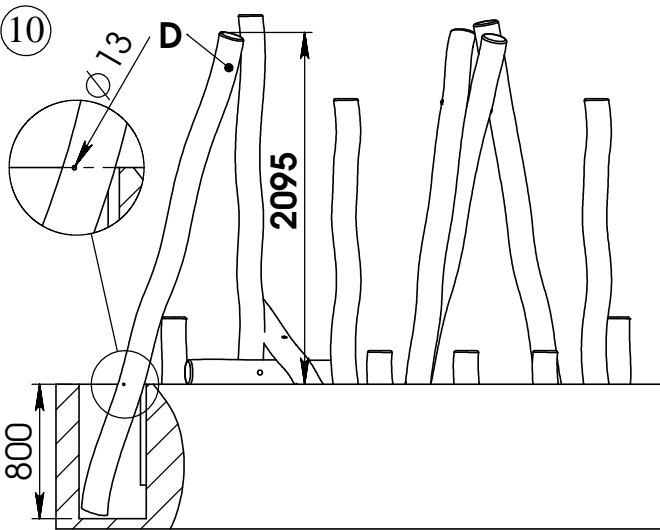

11

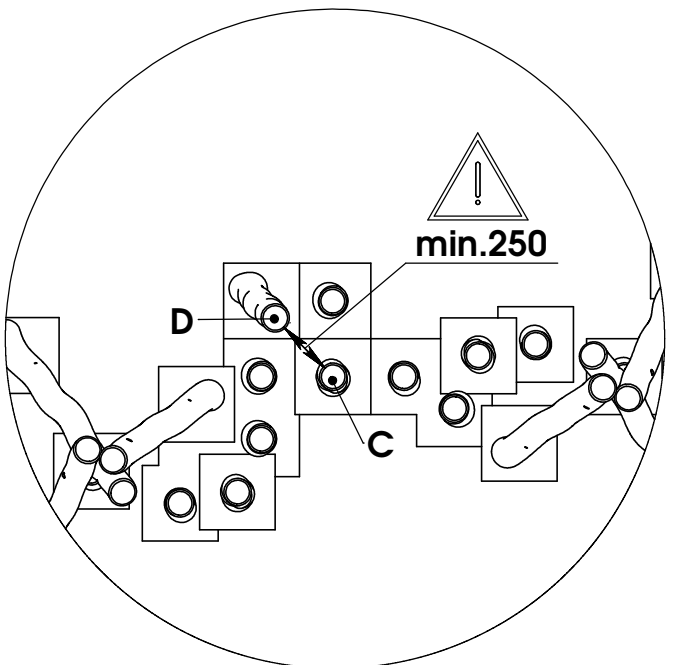
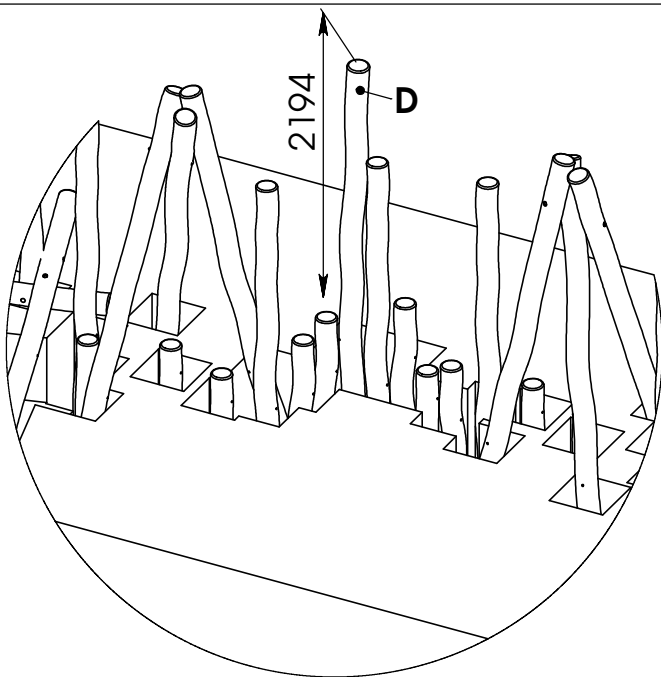
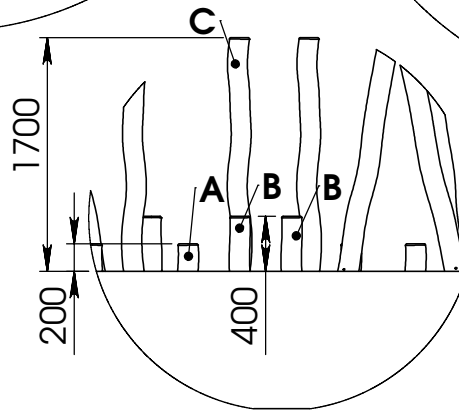
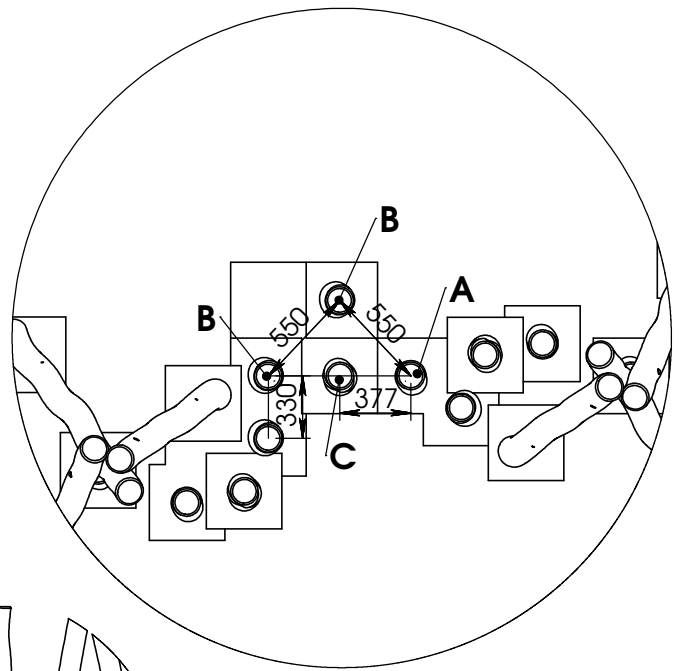
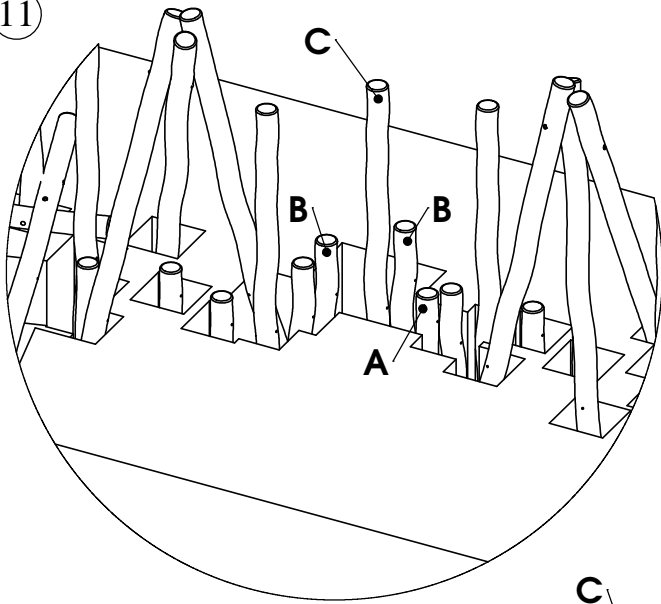

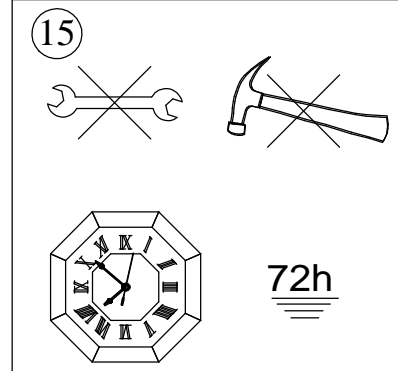
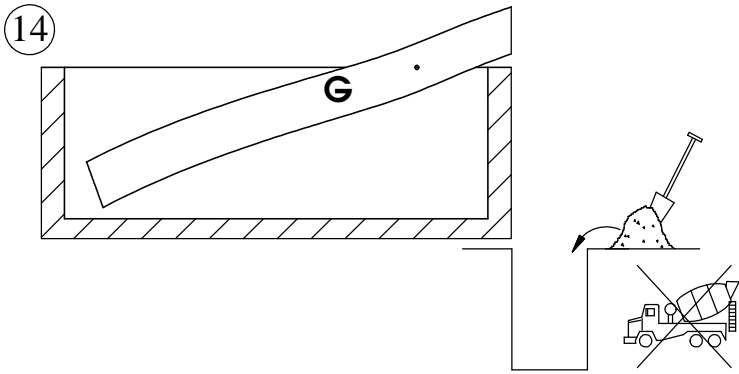
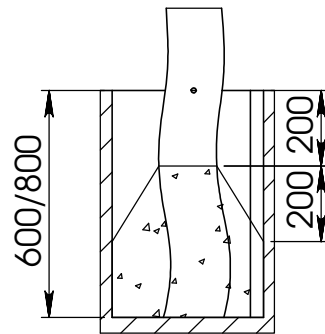
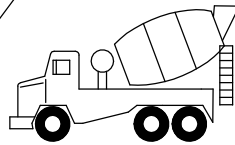
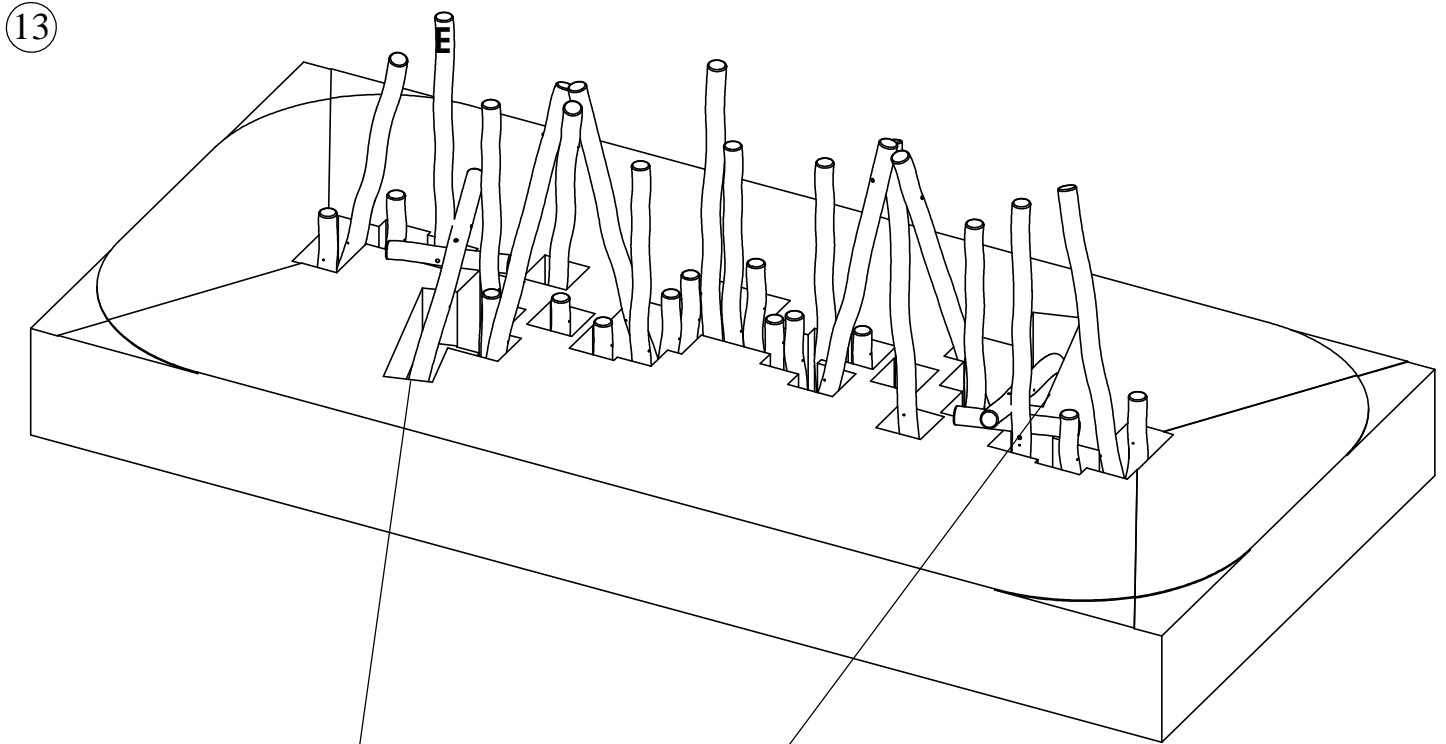

16 Bij droog weer moeten alle bouten en schroeven opnieuw aangespannen worden.
 Par temps sec il faut resserrer régulièrement toute la visserie.
 By dry and warm weather check the tightness of all bolts and screws.
 Bei trockenem Wetter müssen alle Schrauben und Bolzen aufs neue angespannt werden.
 Para el tiempo seco, se necesita cerrar o ajustar los tornillos y tuercas.
 Con tempo asciutto, tutti i bulloni e le viti devono essere avvitati nuovamente.