

# S541

ROVERSHOL  
 NID DE BRIGANDS  
 BANDITS CAVERN  
 RÄUBERHÖHLE  
 NIDE DE BANDIDOS

## Montagehandleiding Notice de montage Assembling manual Montageanleitung

## Instrucciones para el montaje

Leeftijd:  
 Age: 3-12  
 Age group:  
 Alter:  
 Edad:

EUROPLAY nv  
 Eegene 9  
 B-9200 DENDERMONDE  
 tel. 32.52.22 66 22  
 fax.32.52.22 67 22  
 www.europlay.eu

Dat.: 17/09/2012

Page: 1/5

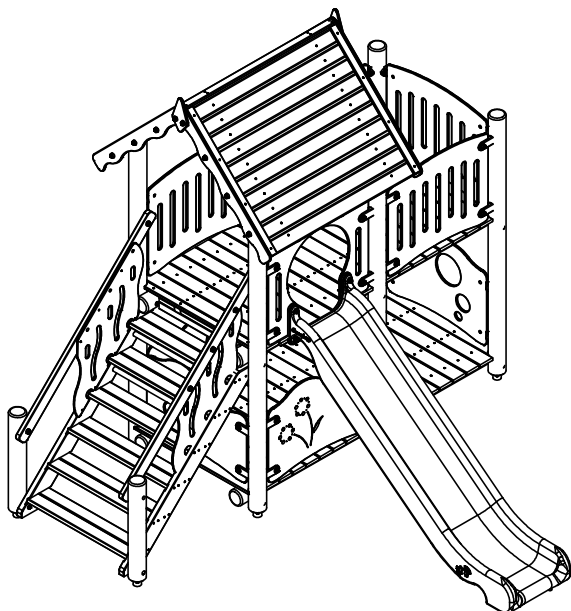

VALHOOGTE / HAUTEUR DE CHUTE  
 FALL HEIGHT / FALLHÖHE / ALTURA DE CAÍDA

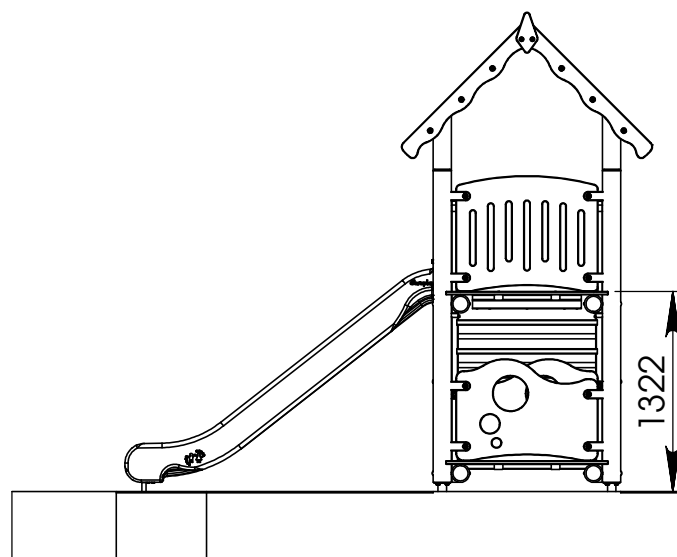



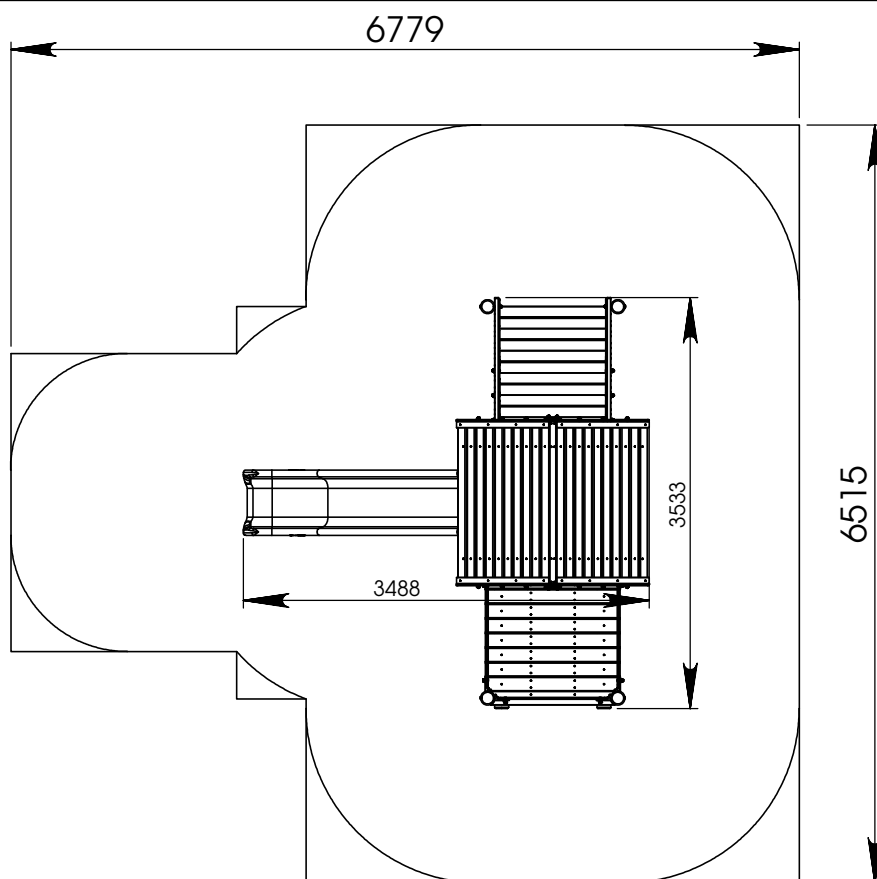

VEILIGHEIDSAFSTAND / ESPACE DE CHUTE / SAFETY AREA /  
 SICHERHEITSAFSTAND / ZONA DE SEGURIDAD

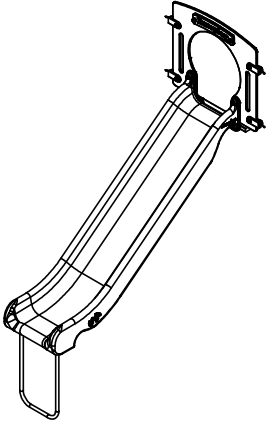
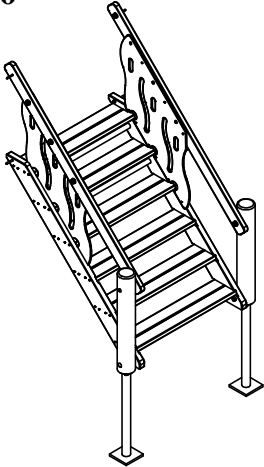
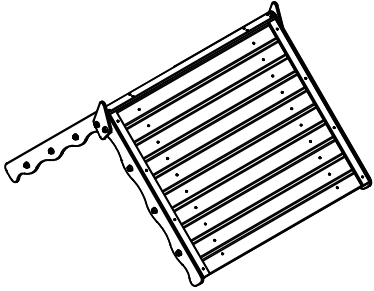
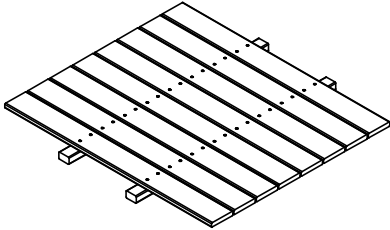
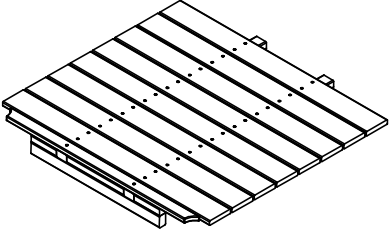
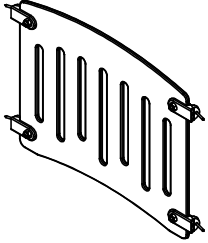
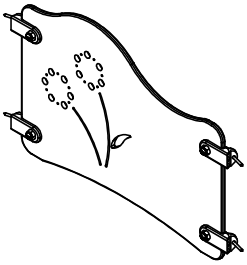
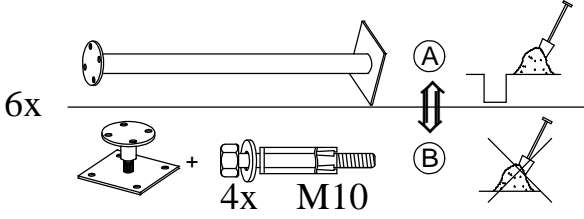
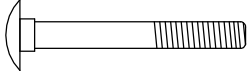

AFMETINGEN  
 DIMENSIONS  
 MASSE  
 DIMENSIONES  
 L : 3,5m  
 H: 3,2m  
 Br: 3,5m

±35m2

Benodigdheden -- Liste des pièces -- Requisites -- Benötigtes -- Accesorios

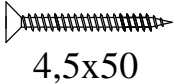
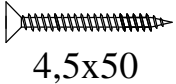
<p><b>G301</b></p>  <p>1x</p>	<p><b>L710</b></p>  <p>1x</p>	<p><b>L771</b></p>  <p>1x</p>
 <p>3x</p>	 <p>±11kg 1x</p>	<p><b>L740</b></p>  <p>4x</p>
<p><b>L760</b></p>  <p>5x</p>		
<p><b>S530-V26</b> Ø120x2480mm 4x</p> <p><b>S431-H-H13</b> Ø120x2420mm 4x</p> <p><b>S540-H-V14</b> Ø120x2070mm 2x</p> <p><b>S530-Vloer-VPE</b> 22x95x1065mm 5x</p>	<p>12x</p>  <p>12x230</p>	<p>12x</p>  <p>M12</p>
<p>12x</p>  <p>M12</p>	<p>12x</p>  <p>M12</p>	<p>12x</p>  <p>M12</p>
<p>90x</p>  <p>4,5x50</p>		

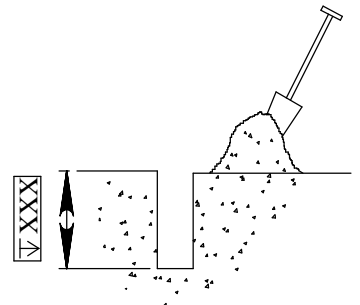
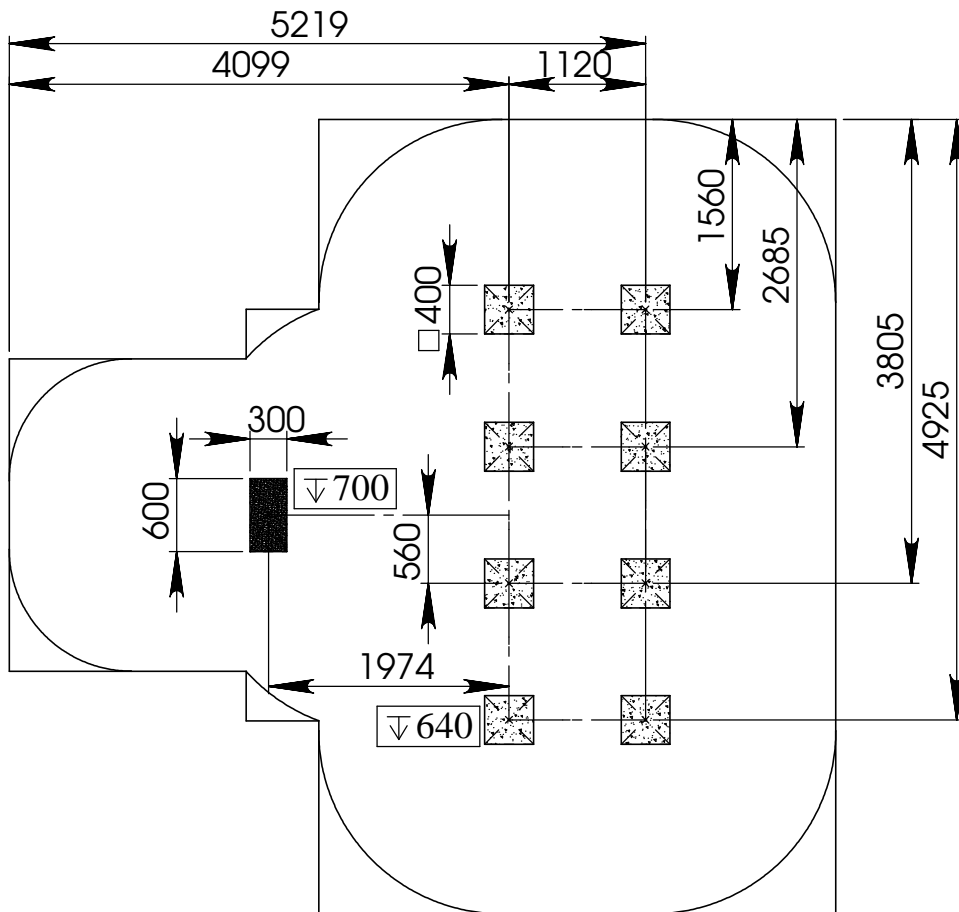
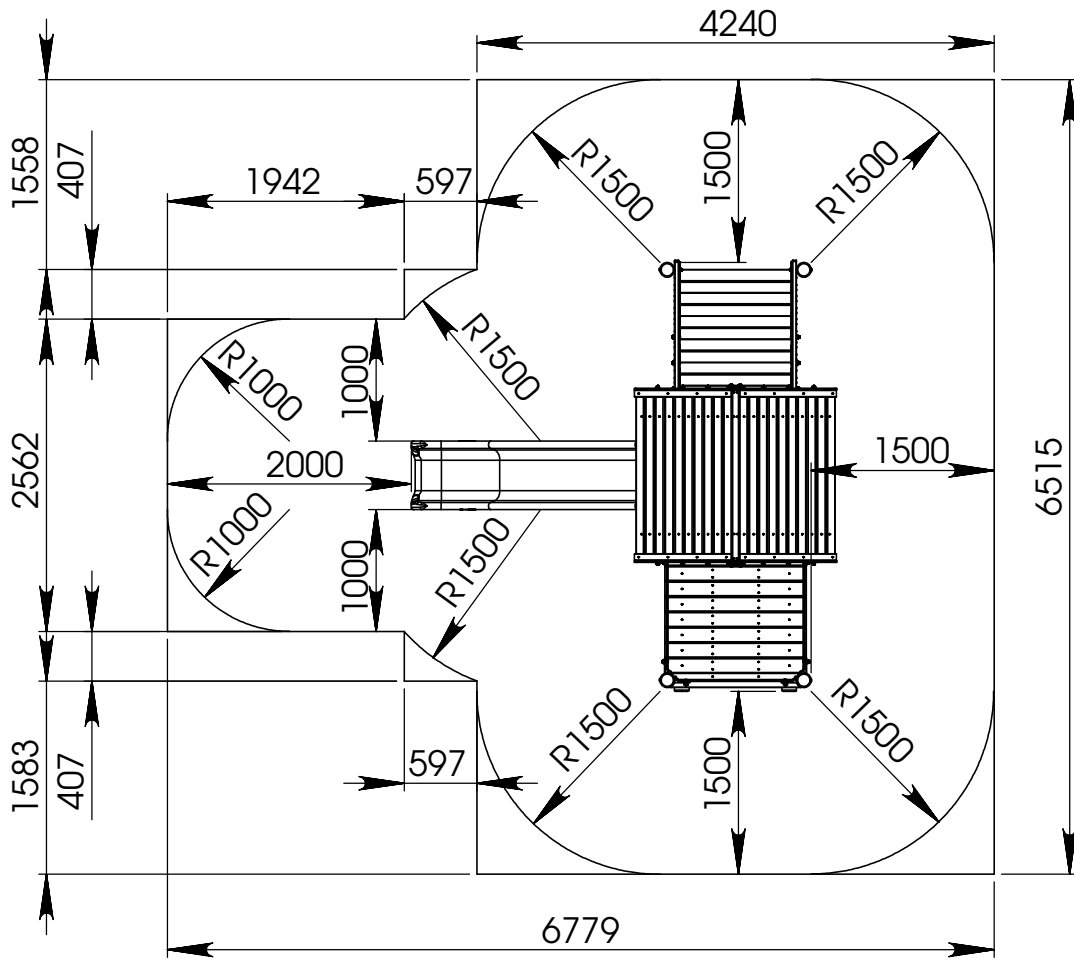

1

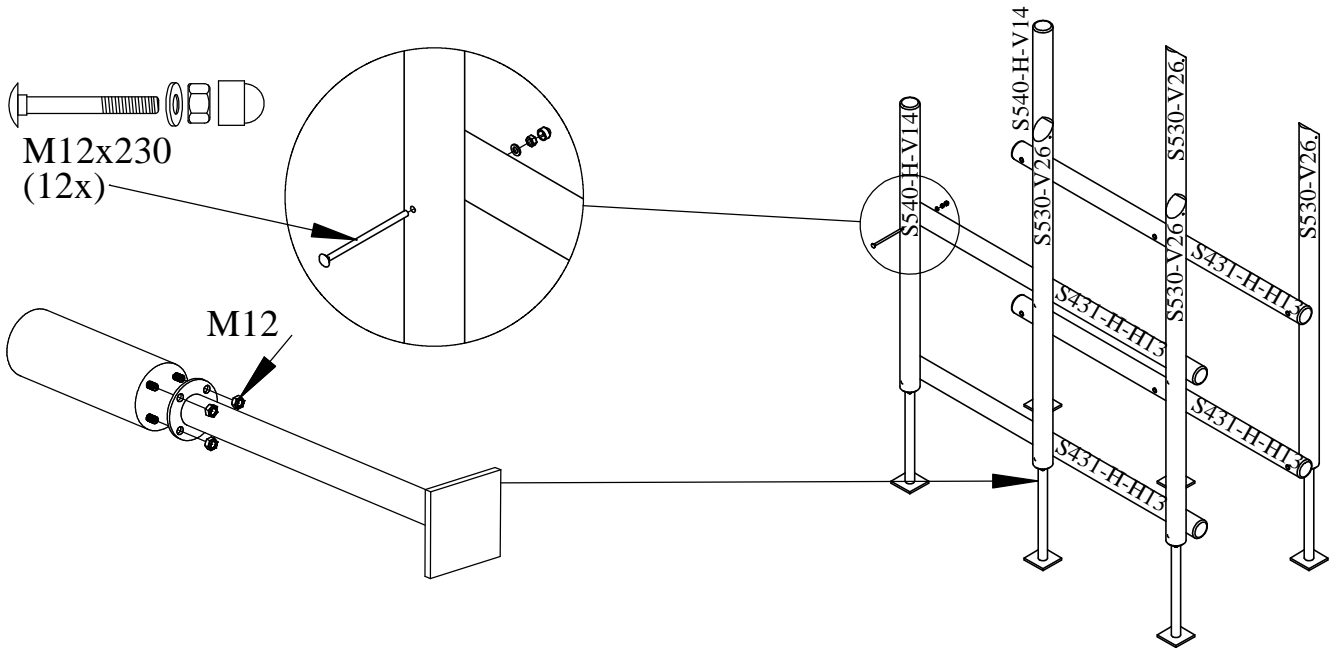

2

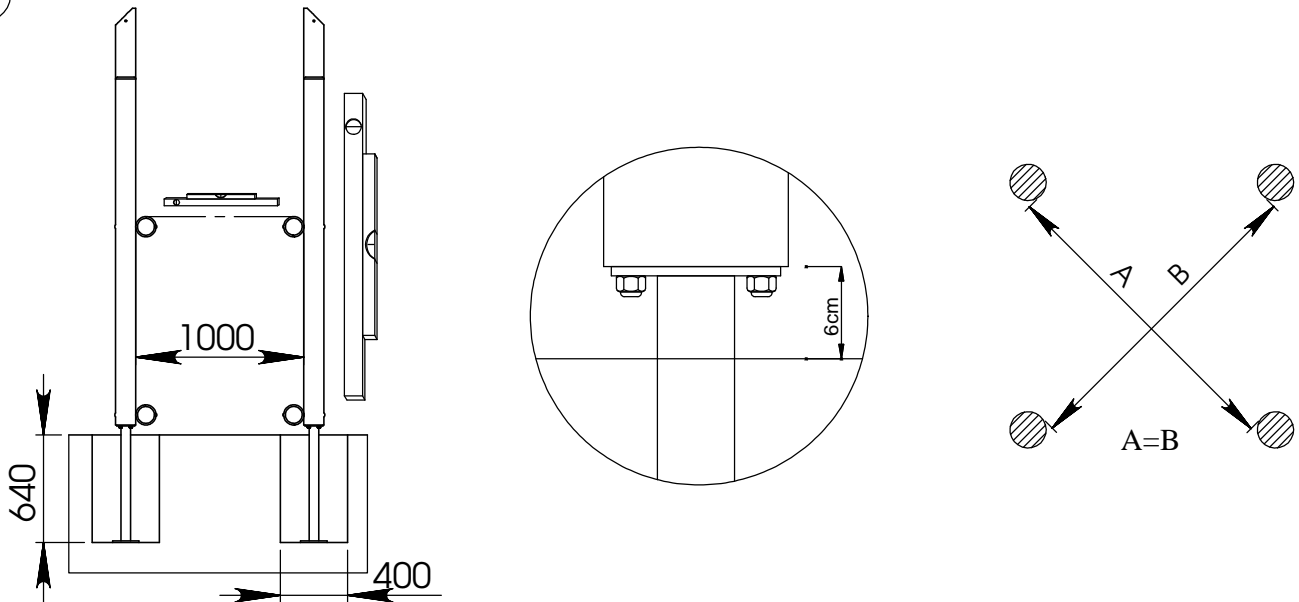

3

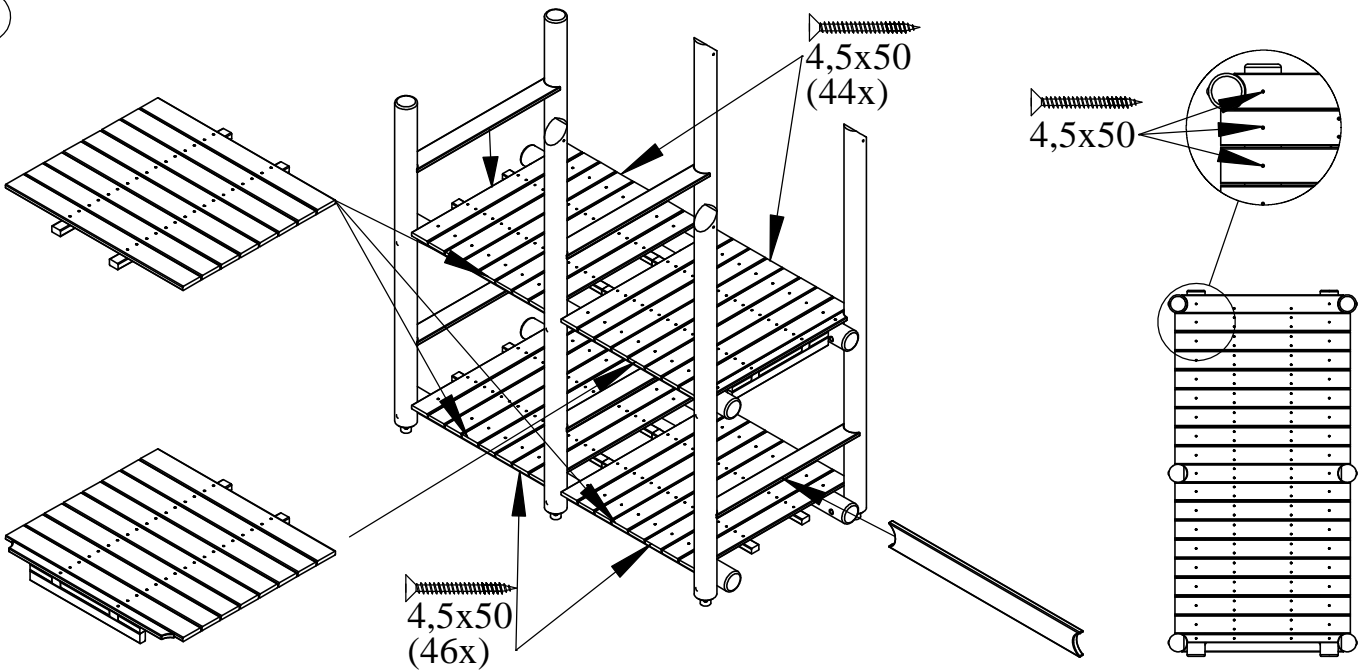

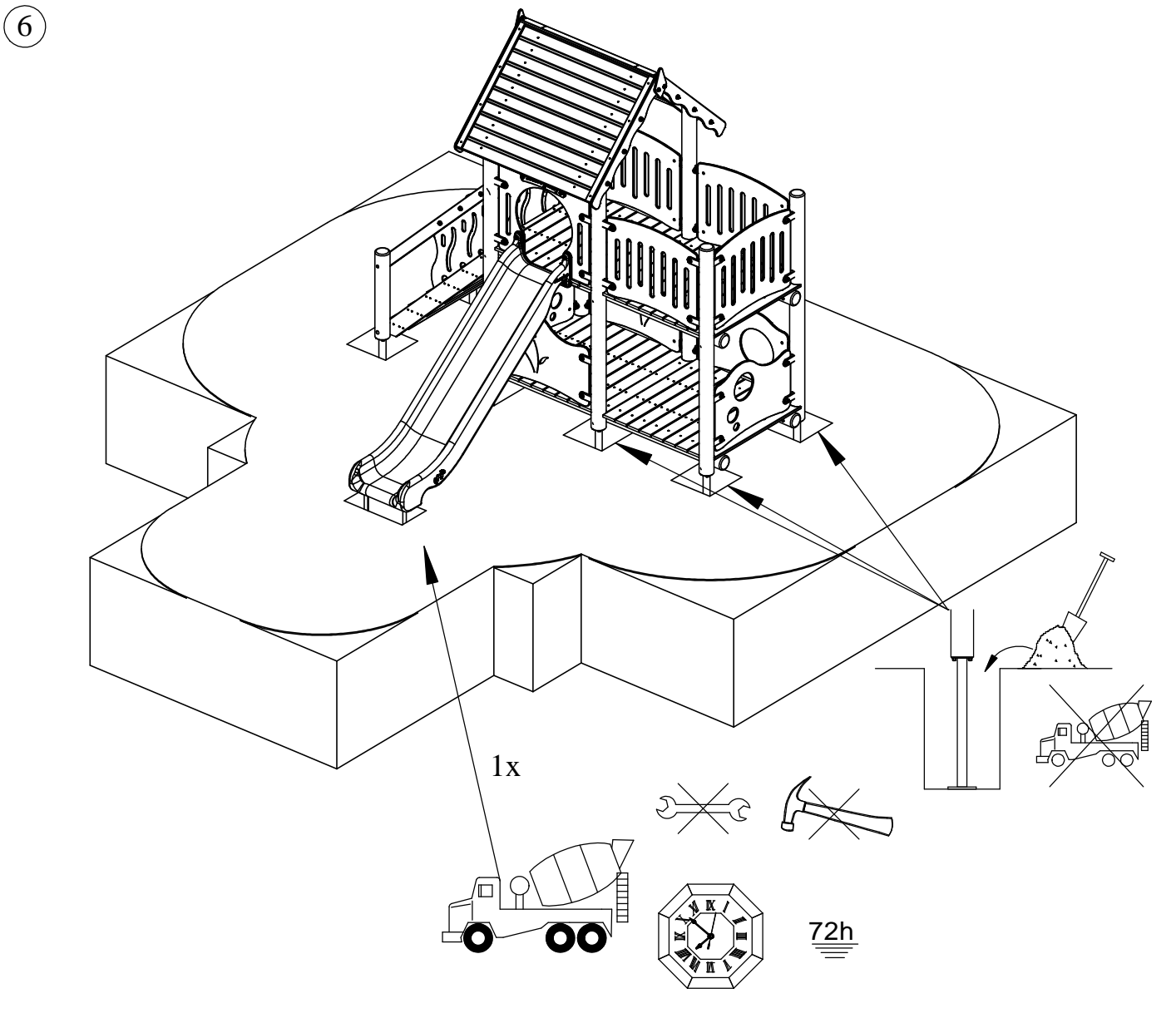
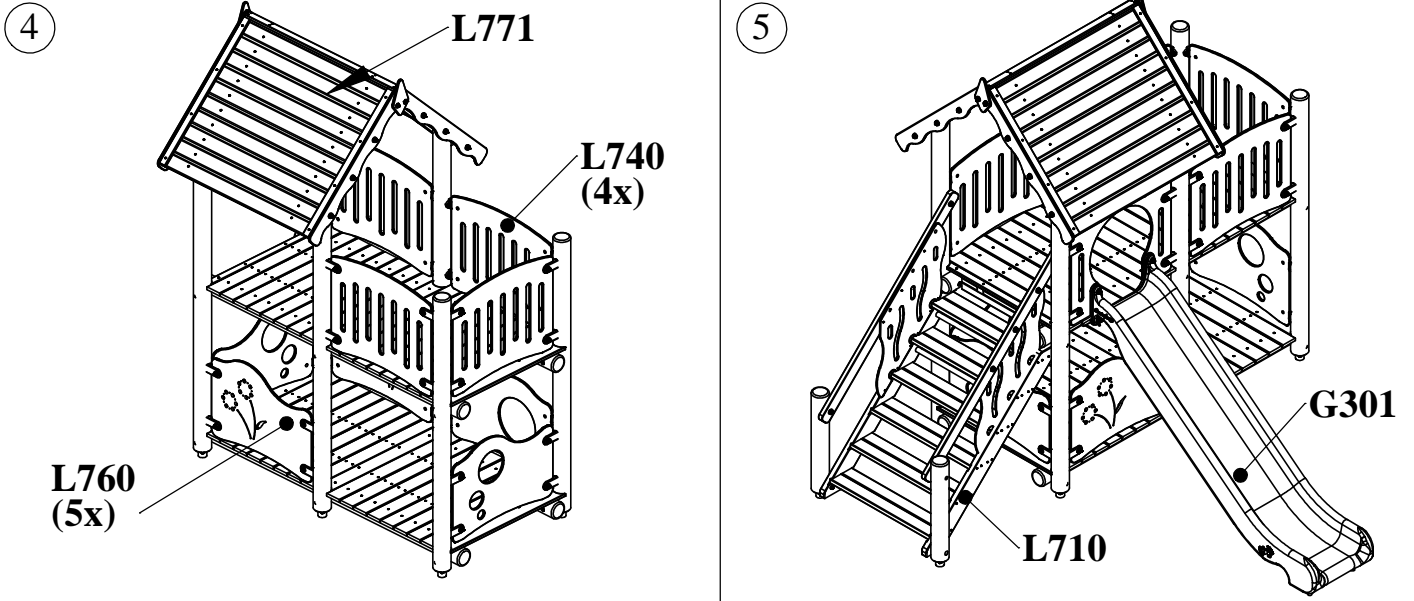

7

Bij droog weer moeten alle bouten en schroeven opnieuw aangespannen worden.  
 Par temps sec il faut resserrer régulièrement toute la visserie.  
 By dry and warm weather check the tightness of all bolts and screws.  
 Bei trockenem Wetter müssen alle Schrauben und Bolzen aufs neue angespannt werden.  
 Para el tiempo seco, se necesita cerrar o ajustar los tornillos y tuercas.