

## Ball catcher

### 25x5 m / 40x5 m „Premium“

#### Thank you very much for choosing a Sport-Thieme product!

Please read the instructions fully before you assemble the equipment, so you can enjoy the product and safety is guaranteed. We are happy to answer any questions you may have.



**Note:** Before mounting you ought to check if the supply is complete and undamaged. Reclamations work only within 24 hours due to reasons of the assurances.



#### A ball catcher consists of the following parts:

(number of pieces depending on the order)

1		post	depending on the order	
2		post fixing	1 per post	
3		cross plate	1 per post	
4		cover plates	1 per post	
5		slut nut M8	2 per post	
6		hexagon screw DIN 933 - M8x12	1 per post	
7		washer M8	1 per post	
8		steel profile for post stiffening Ø88,9x2,9	1 per post	from 5m post length
9		drilling screw with hexagon socket 4,8x32	2 per steel profile	
10		ring screw DIN 580 - M8x30	1 per post	
11		slanting supports with straps	2	optional available
12		slanting supports without straps	2	optional available

## A ball catcher consists of the following parts:

(number of pieces depending on the order)

13		drilling screw with hexagon socket 4,8x32	2 per slanting support	accessory slanting support
14		slot nut M8	8 per slanting support	accessory slanting support
15		connector	4 per slanting support	accessory slanting support
16		hexagon screw DIN 933 - M8x16	8 per slanting support	accessory slanting support
17		hexagon screw DIN 933 - M10x60	4 per slanting support	accessory slanting support
18		washer DIN 125 M10	12 per slanting support	accessory slanting support
19		hexagon nut DIN985 - M10	4 per slanting support	accessory slanting support
20		steel rope	1	one more optional available
21		thimble	2 per 25m rope	accessory tensioning rope
22		clamp	4 per 25m rope	accessory tensioning rope
23		rope tensioner	1 per 25m rope	accessory tensioning rope
24		carabiner hook	1 pro 25m rope & per post	accessory tensioning rope
25		carabiner hook		accessory tensioning rope
26		traverse octagon profile	per post	optional available
27		threaded plate M10	2 per traverse	accessory traverse
28		hexagon screw DIN 933 - M10x20	2 per traverse	accessory traverse
29		washer M10	2 per traverse	accessory traverse
30		net	depending on the order	
31		net holder	depending of net	
32		ground sleeve	1 per post	
33		post sample item approx. 1,5m	1	alignment aid for the ground sleeves during concreting

## required tools:

1	shovel	
2	concrete C20/25 at foundation size	
3	13 wrench	
4	17 wrench	
5	19 wrench	
6	hydraulic ramps	
7	bolt cutter	
8	Cordless screwdriver with socket wrench	
9	safety gloves	Danger of cutting on the profile
10	safety shoes	

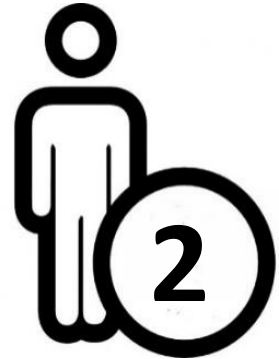

# Assembly instructions for Art.-Nr. 249 4920

*We are your team!*

## assembly

- foundations of concrete C20 / 25
- For the foundation size see page: 9
- the profile groove points to the field

When pouring the foundations install a drainage for dewatering the ground sleeves! E.g. a piece of round tube.

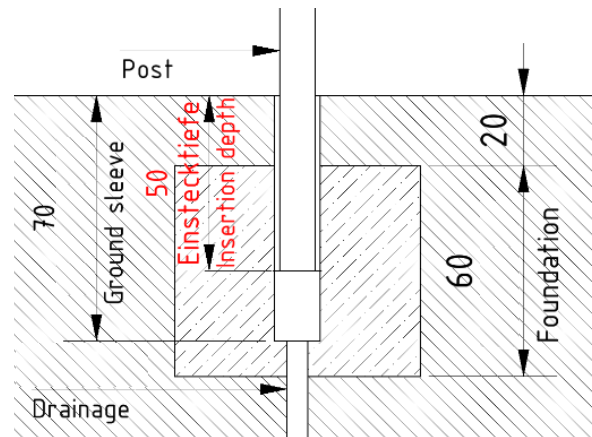

1. Insert the small hook of the cross plate (3) into the recess provided from the post mounting (2) and slide both together into the openings of the cover plate (4).

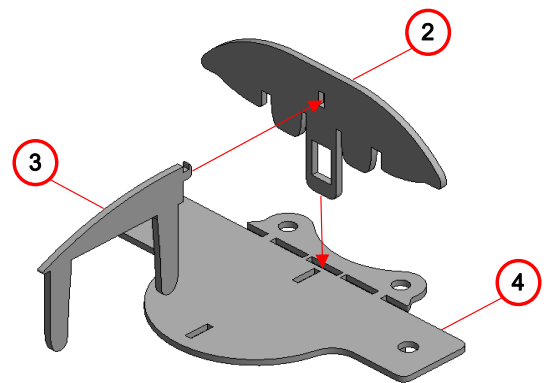

2. Place the slot nut M8 (5) into the opening of the post fitting.

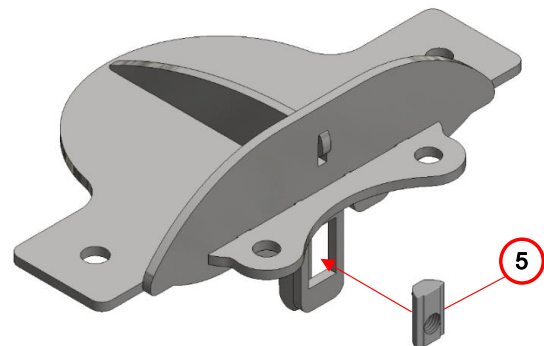

3. Slide the finished post cover and the slot nut M8 (5) located in it into the groove of the post. Screw the hexagon socket screw M8x12 (6) with the washer M8 (7) into the slot nut M8 (5). Tighten the screw so that the cover is no longer removable from the post.

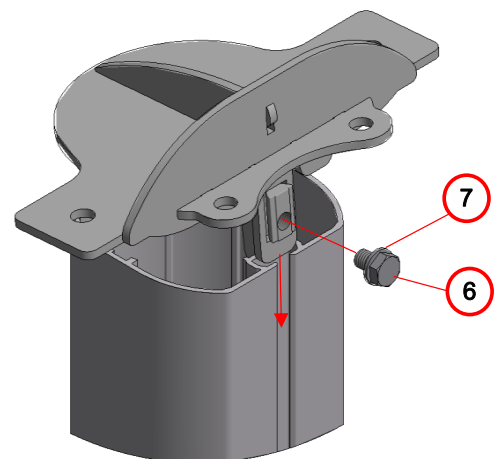

# Assembly instructions for Art.-Nr. 249 4920

*We are your team!*

4. Preparing the work step 12 below in the groove of the post ① insert a slot nut M8 ⑤ and fix provisionally with Ring bolt ⑩ 60 cm from the bottom edge.

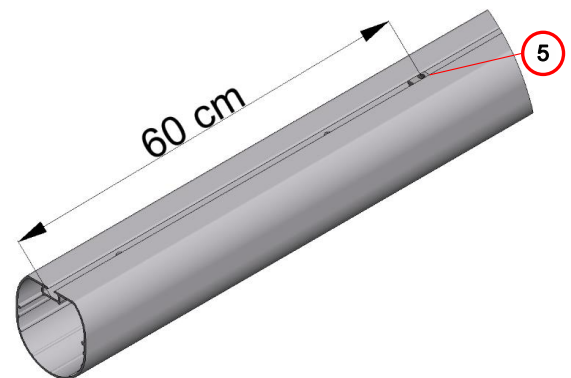

5. At a post height above ground from 5m:

The steel profile ⑧ flush in the posts insertion. With 2 self-drilling screws ⑨ fixed in the groove, so that the screw head disappears in the groove.

6. Set the posts ① into ground sleeves:  
The profile groove points to the field! We recommend to put up the posts ① with a minimum of two persons.  
**Note:** Steps 7 to 9 explain the installation of the slanting support. This is **optional!**

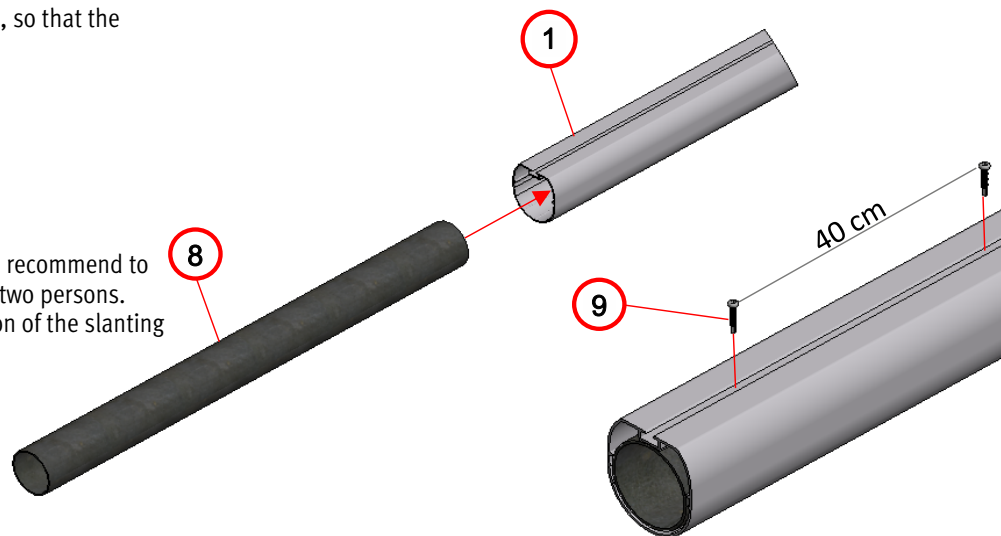

7. The slanting supports ⑪/⑫ supplied in 2 parts are connected with the welded-on straps and secure the connection with 2 drill screws ⑬.

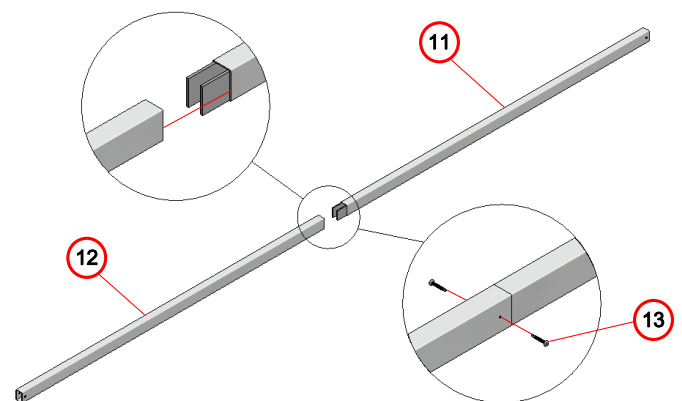

8. Press two slot nut M8 ⑭ above in the outermost post and below in the second post from the outside.

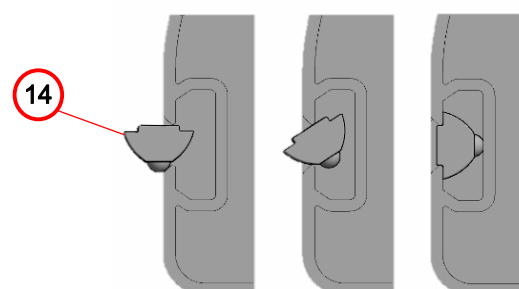

9. Fasten the connectors to the up-rights with hexagon screw M8x16 (16), respectively, using slot nut M8 (14). Fit the slanting support on the connectors (15) using hexagon screw M10x60 (17), washer M10 (18) and hexagon nuts M10 (19):
- At the top of the outer post,
  - At the bottom of both second posts from the outside.

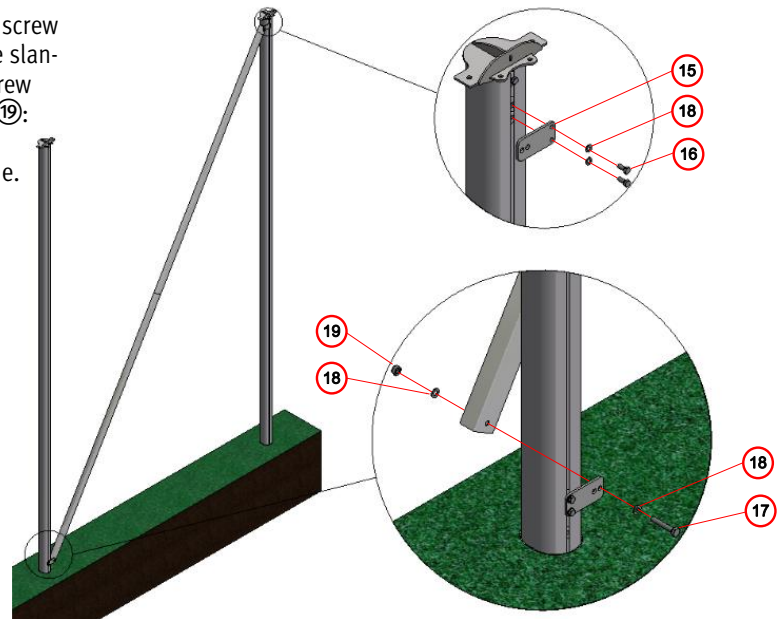

## 10. Making the upper net tension

### variant 1 - with Steel tensioning rope:

- Recommendation: Steel rope (20) only over max. 25m tighten.

First, turn the rope tensioners (23) so far that they have a reserve of about 3cm. Thread the steel rope (20) with one end and the thimble (21) through an eyelet of the rope tensioner (23) and make the rope to a loop. Use two clamps (22) to clamp the tensioning rope (20). On the other side of the rope tensioner (23) hook a carabiner hook (24). Hook the carabiner hook into a ring screw. Take the steel rope and pass it by the post, tighten it by hand and cut off it after approx. 25.5m. Place the other end of the tensioning rope (20) with a further thimble (21) to a loop and clamping with two clamp (22). Hook a carabiner hook (24) into the loop.

The tensioning rope with the carabiner hooks hook into the holes of the outermost post cover. On each post the steel rope passes, hook a carabiner hook into the post cover and hang in the steel rope. Hook the end of the tensioning rope with the carabiner hook into the last reachable post cover. Finally, hold tight the tensioning rope and by turn the tension key to tightening the tensioning rope.

**Note:** When tighten the steel rope, it must not twist. It can happen, that the tension solve again.

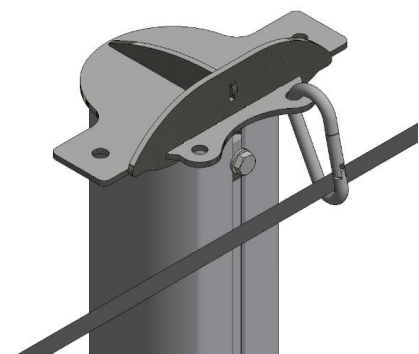
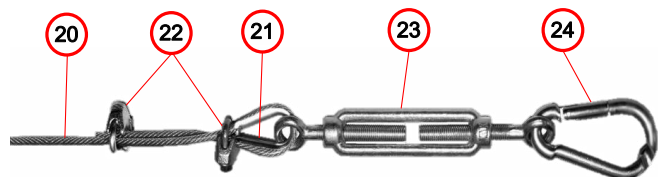

### variant 2 - with continuous traverse:

- Insert two threaded plates M10 (27) into the profile groove of the cross-traverse (26). Use the hexagon screw M10x20 (28), washers M10 (29) and threaded plate M10 (27) to screw the cross-traverse (26) and post cover firmly.

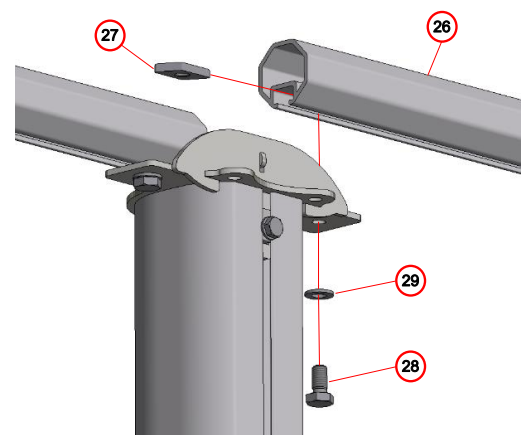

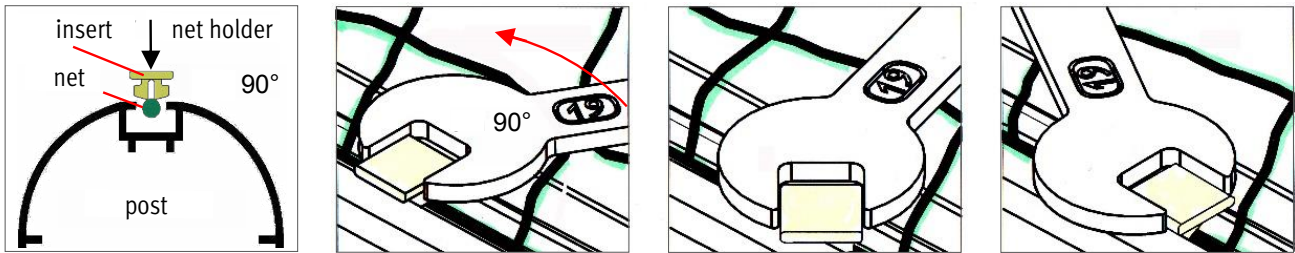

## 11. hanging the net

- **with variant 1:** Press the net edge reinforcement rope together with the net hooks (31) into the profile groove on the outer post (1) and turn the net hooks (31) 90° (e.g. with the SW19 wrench). With the carabiner hook (25) the net is attached to the upper tensioning rope (20).
- **with variant 2:** Press the net edge reinforcement rope together with the mains net hooks (31) into the profile groove on the outer post (1) and the traverse octagon profile (26) and turn the net holder (31) 90° (e.g. with the SW19 wrench).



## 12. establish lower net tension:

Recommendation: Steel rope (20) only over max. 25m tension.

- First of all, they turn the rope tensioners (23) so far that they have a reserve of about 3cm. Thread the steel rope (20) with one end and the thimble (21) through an eyelet of the rope tensioner (23) and make the rope to a loop. Use two clamps (22) to clamp the tensioning rope (20). On the other side of the rope tensioner (23) hook a karabiner hook (24).
- Hook the tensioning rope with the carabiner hooks into the ring screw M8 (10) of the outermost post. Thread the steel rope through the meshes of the net and through all the ring screws (10) of the posts on which the steel rope passes. Per hand tighten and cut off after approx. 25.5m length. At the last reached post, attach the end of the tensioning rope (20) to a loop using a further thimble (21) and clamping with two clamps (22). Hook a carabiner hook (24) into the loop and into the ring screw.
- Finally, hold tight the tensioning rope and by turn the tension key to tightening the tensioning rope.

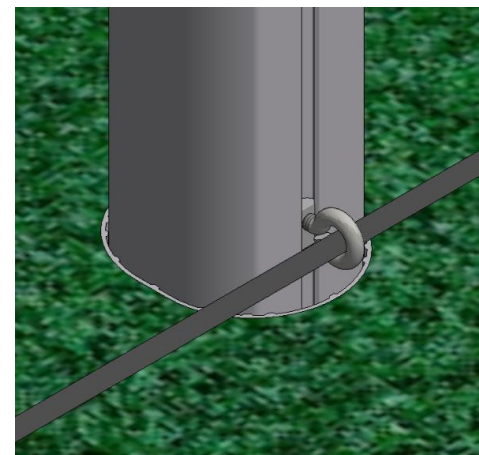
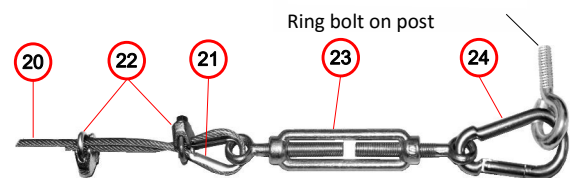

**Note:** When tighten the steel rope, it must not twist. It can happen, that the tension solve again.

**Attention:** The rope tensioners (23) should lie outside the net mesh!

## Maintenance instructions

- Once a month the screws must be checked and possibly tightened.
- Regular checks on damage and breaking points

### Torque:

For M8-screws: 16Nm

For M10-screws: 32Nm

## assembly of a ball catcher with cross-traverses

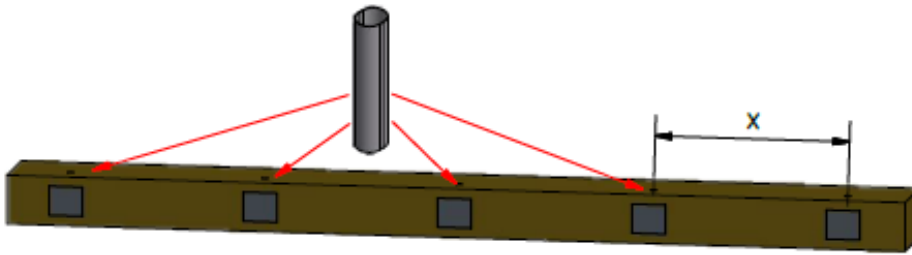

1. ground sleeve concreting

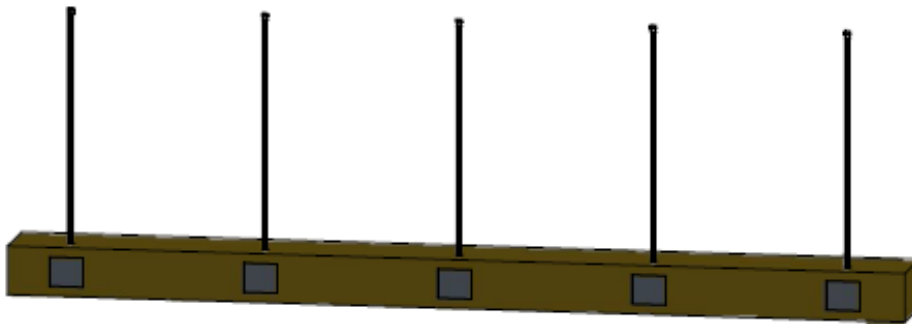

2. set up the posts

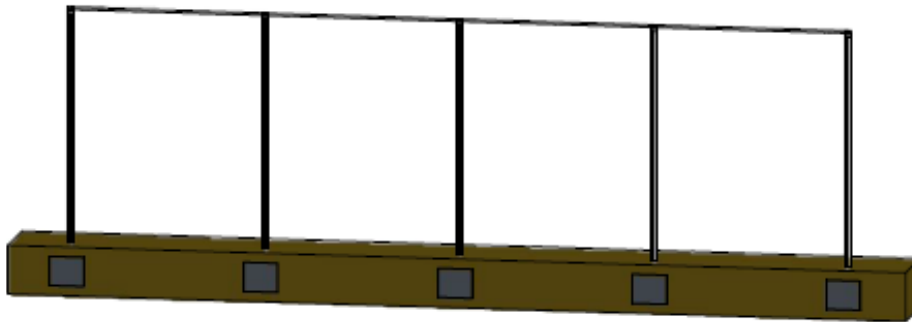

3. install the cross traverse or tighten the tension rope

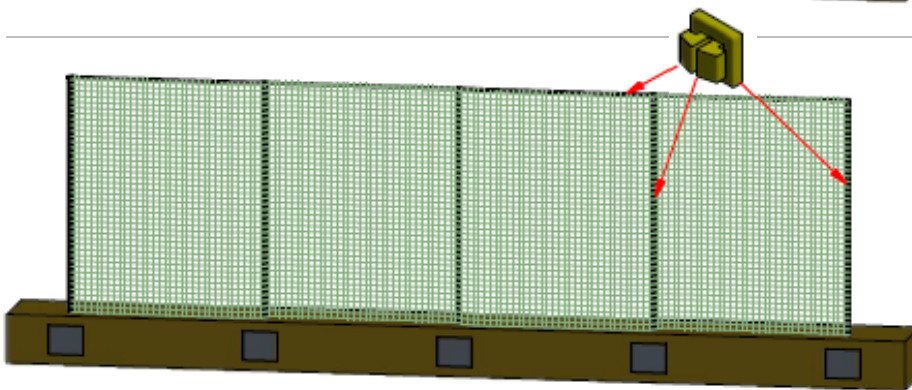

4. fasten the net with net hooks to the posts and cross traverse

at systems with tensioning rope, the net is hooked onto the tensioning rope with carabiner hooks

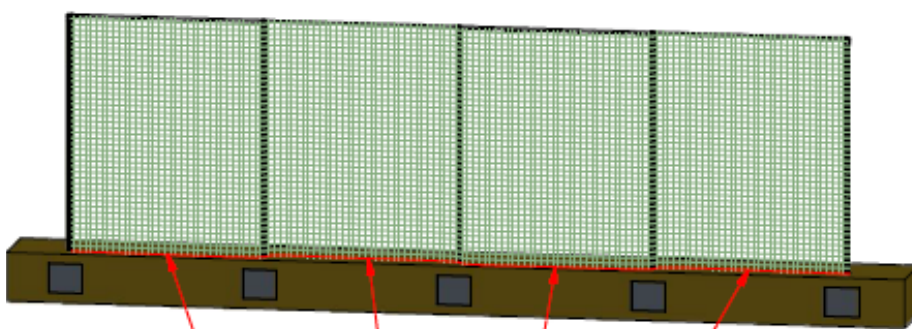

5. Divide the tensioning rope and pass through the lowest row of mesh. Tension rope max. 25m



# Assembly instructions for Art.-Nr. 249 4920

## technical data

### post profile

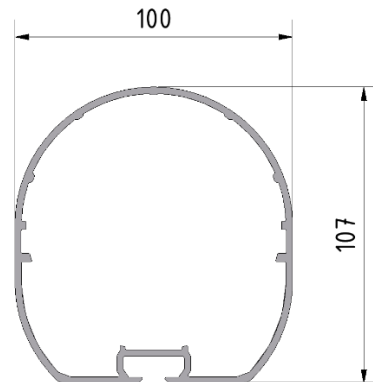

### field

The concrete point foundations should consist of C20/25. The foundations should be cast 20cm below the top edge of the ground. The ground sleeves should be flush with the field surface.

## foundation

Please note that during the casting of the foundation a dewatering possibility (drainage) is installed, e.g. a piece of round tube.

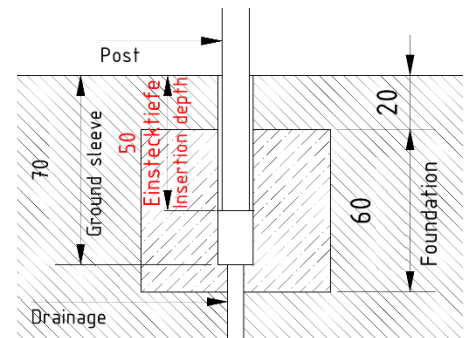
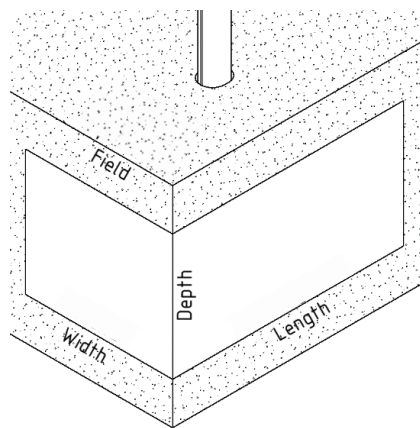

## dimension

### Net size 100x100x3

Sleeve length / Insertion depth	Height Above ground	Post distance (Dimension between axes)	Size of concrete foundation Length / Width / Depth
70cm / 50cm	3,00m	5,00m	70x70x60cm
70cm / 50cm	3,50m	5,00m	80x70x60cm
70cm / 50cm	4,00m	5,00m	90x70x60cm
70cm / 50cm	4,50m	5,00m	100x70x60cm
70cm / 50cm	5,00m	5,00m	110x70x60cm
70cm / 50cm	5,50m	4,50m	115x70x60cm
70cm / 50cm	6,00m	4,50m	120x70x60cm
70cm / 50cm	6,50m	4,50m	135x70x60cm
70cm / 50cm	7,00m	4,50m	145x70x60cm

### Net size 120x120x3

Sleeve depth / Insertion depth	Height Above ground	Post distance (Dimension between axes)	Size of concrete foundation Width / Length / Depth
70cm / 50cm	3,00m	5,00m	70x70x60cm
70cm / 50cm	3,50m	5,00m	70x70x60cm
70cm / 50cm	4,00m	5,00m	80x70x60cm
70cm / 50cm	4,50m	5,00m	90x70x60cm
70cm / 50cm	5,00m	5,00m	100x70x60cm
70cm / 50cm	5,50m	4,50m	105x70x60cm
70cm / 50cm	6,00m	4,50m	115x70x60cm
70cm / 50cm	6,50m	4,50m	120x70x60cm
70cm / 50cm	7,00m	4,50m	130x70x60cm

**Note:**

The foundation size are for the wind load zone 2 and a ground pressing of 150kN/qm<sup>2</sup>